

Unity Low Voltage Disconnect & Monitor

Installation/Operation Manual

Model: ULM-100



Table of Contents

	Page	Table of Contents	Page
1.0 Overview	2	5.14 LVD Level Mapping	4
2.0 Materials Provided	2	5.2 Meter	4
3.0 Mounting	2	5.21 Voltage Monitoring	4
3.1 Rack Ears	2	5.23 Backlighting Adjustment	4
4.0 Wiring	2	5.24 Temperature Monitoring	4
4.1 Rectifier Input	2	5.25 Meter Power Source Selector	4
4.2 Battery Input	2	5.26 Restore to Factory Settings	5
4.3 Load Output	2	5.3 Battery Circuit Breaker	5
4.4 Alarms	3	5.4 Alarm LED	5
5.0 Operation & Adjustments	3	6.0 Connecting Rectifier Types	5
5.1 Low Voltage Disconnect	3	6.1 Unity Rectifier Shelf (URS)	5
5.1 Manual/Auto Selector Switch	4	6.2 Power Modules (PM Series)	5
5.12 LVD Adjustment	4	7.0 Troubleshooting	6
5.13 LVD Alarms: Pre-Disconnect & Disconnect	4	8.0 Specifications	6
		9.0 Outline & Mounting Drawing	7

M-ULM100
030315

1.0 Overview

This 1RU assembly contains numerous DC control and monitoring features that integrate power and distribution components into a highly functional system. Built in features include: low voltage disconnect, digital monitor of voltage and amperage, battery disconnect breaker, and alarm contacts. The digital display monitors bus voltage, battery voltage, system output current, and low voltage connect/disconnect set points. Alarm contacts actuate on low voltage and battery disconnect conditions. Rear panel bus bars provide ample terminal landings for easy integration with rack mount rectifiers, distribution panels and batteries.

Figure 1: Overview - Front Panel

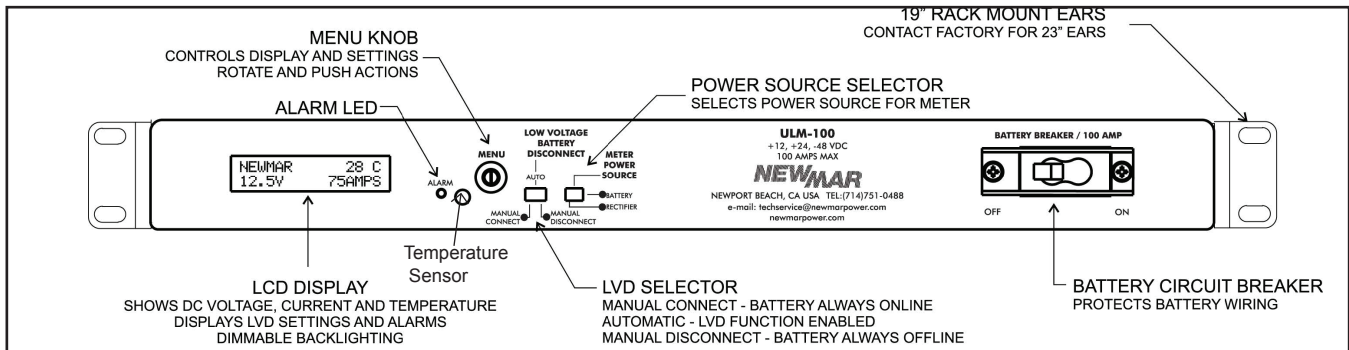

2.0 Materials Provided

Qty.	Description
2	Mounting ears for 19" rack mounting (Note: Contact Newmar Technical Support for 23" rack mount ears)
6	6-32 x 3/8" Phillips head screws, black-mount the two mntg. ears
1	Molex pigtail alarm connector/wire assembly (six wires)
10	1/4-20 Hex Head bolt for rectifier, battery input & load connection
10	1/4" split lock washer - one per 1/4-20 Hex Head bolt above
1	Installation/Operation Manual

3.0 Mounting

3.1 Rack Ears: One pair of rack ears for 19" rack mounting are provided. Optional 23" rack mounting ears are available - please contact Newmar for p/n 699-3918-0, qty. 2. Two mounting options are available: Flush mount and 6" off-set or 'center mount'.

4.0 Wiring

Figure 2: Wiring - Rear Panel

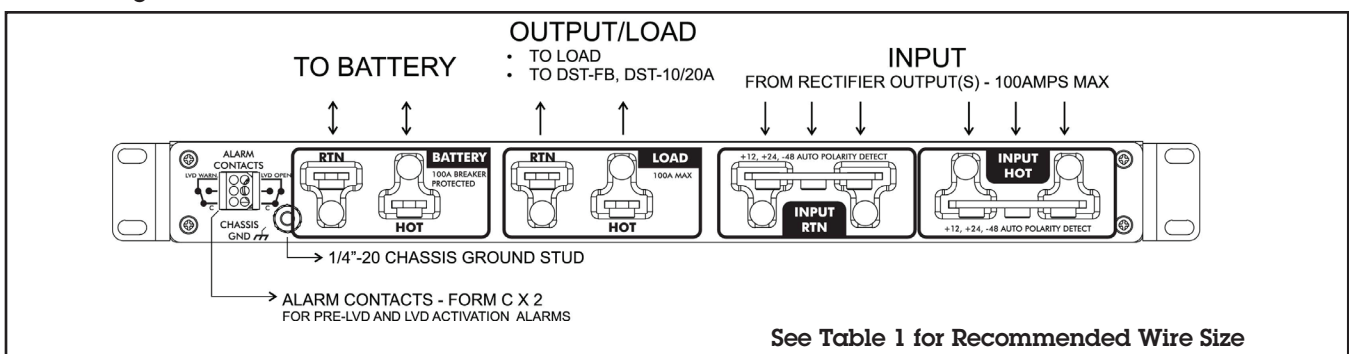

4.1 Rectifier Input: Three sets of landings for 1/4" ring lug terminals are provided for rectifier Hot and RTN input connections. Maximum total rectifier current is 100 Amps. See section 6.0 for more information on connecting Newmar rectifiers.

4.2 Battery input: One pair of landings for 1/4" ring lug terminals are provided for connecting the battery. The ULM-100 incorporates a 100 Amp battery breaker on the front panel however for long battery cable runs we recommend a fuse or breaker wired on the battery hot side, located as close to the battery as practical.

4.3 Load output: One pair of landings for 1/4" ring lug terminals are provided for connecting the load or feeding a distribution panel such as Newmar model DST-FB, DST-10, DST-20A or FDP fuse panels. Maximum load current is 100 Amps.

Table 1: Wire Size Chart

Amperage	Minimum Wire Size in AWG
1-10A	#16
11-20A	#14
21-30A	#12
31-35A	#10
36-50A	#8
51-70A	#6
71-90A	#4
91-100A	#2

4.4 Alarms: Pre-disconnect & Disconnect- Two sets of Form C alarm contacts are provided for the following: Pre-LVD Disconnect & LVD Disconnect. Wiring is via the Molex six conductor alarm wire pigtail included with the ULM-100. See section 5.12 & 5.13 for information on setting Pre-disconnect and LVD activation thresholds.

5.0 Operation & Adjustments

Figure 3: LCD Menu

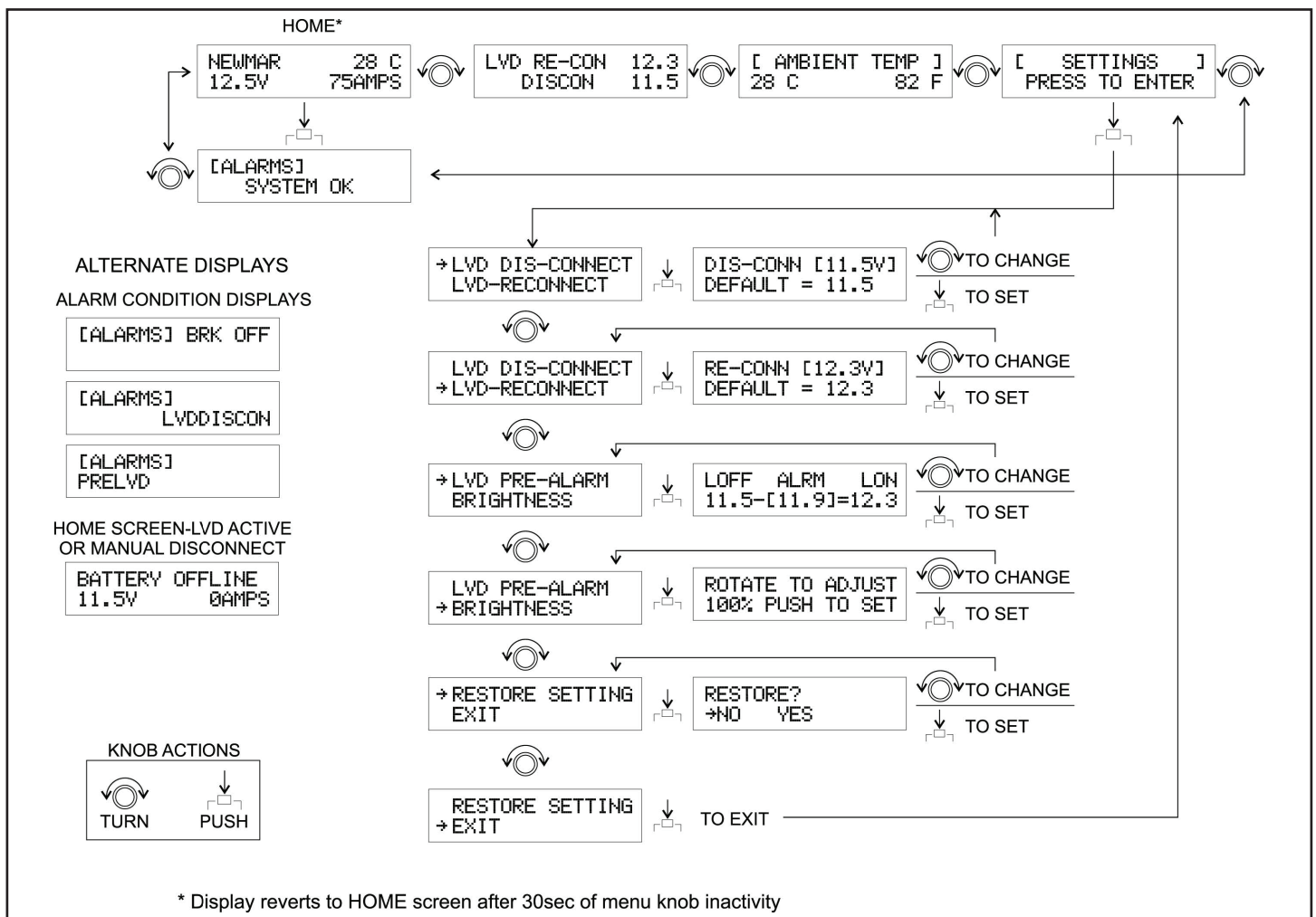

5.1 Low Voltage Disconnect: The ULM-100 incorporates a 100 Amp solid state LVD circuit which automatically removes the battery when battery voltage drops to a pre-set DISCONNECT threshold (or when manually activated- see section 5.11) and automatically re-connects the battery when battery voltage rises above the selected CONNECT threshold (see Specification 8.0 for default LVD thresholds and adjustment ranges)

5.11 Manual/Auto selector switch: The LVD selector switch sets the way the LVD circuit functions.

- Manual connect - Battery always online
- Automatic - LVD function enabled (factory default)
- Manual disconnect - Battery always offline

5.12 LVD Adjustment: The ULM-100 offers easy adjustment of both dis-connect and re-connect LVD settings without the need for an external, adjustable power supply. These thresholds can be selected from the SETTINGS page using the menu knob, the default factory setting for the particular item is also displayed. A press on the menu knob will save the settings and is retained even after powering down the unit. LVD threshold adjustment can be made while the system is operating.

5.13 LVD Alarms: Pre-disconnect & disconnect - Two external alarms can be triggered by the ULM-100: the Pre-disconnect ('PRELVD') and the LVD dis-connect ('LVDDISCON'). The LVD Pre-disconnect alarm is a warning to an impending battery disconnect. It is triggered by an adjustable voltage thresholds set above the LVD dis-connect threshold and below the re-connect threshold. The LVD dis-connect alarm is automatically set using the LVD dis-connect threshold (see 5.12). Both alarms will trigger the LED Alarm light.

5.14 Voltage Level Mapping - 12 VDC example shown

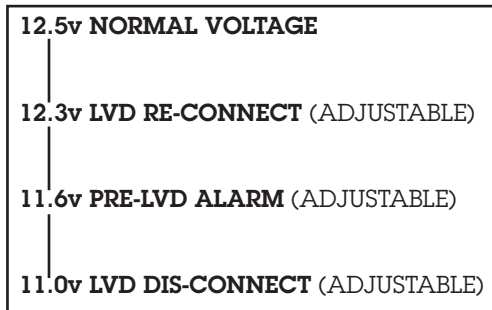

Normal Voltage - Typical system voltage with rectifiers supplying load(s), batteries not deeply discharged.

LVD Re-Connect - Level at which the battery will be re-connected after a dis-connect event when AC power is restored.

Pre-LVD Alarm - Level at which the pre-LVD alarm contact triggers as an early warning for a low battery disconnect. (See Specification Section 8.0 for factory default.)

LVD Dis-Connect - Minimum allowable battery voltage level has been reached and will disconnect battery to prevent damage. Will also trigger LVD alarm. (See Specification Section 8.0 for factory default.)

5.2 Meter

Figure 4: LCD Home Screen

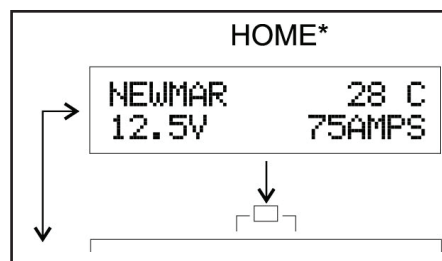

5.21 The home screen shows DC voltage, DC current and Ambient temperature in degrees Celsius. The display always returns to the home screen after 30 seconds of inactivity. A push of the menu button will display the alarm screen and rotating the knob will send it to adjacent display pages.

5.22 Plant Current Monitoring: The total current being produced by the rectifier(s) connected is displayed on the main screen. This includes current drawn by the load and battery charging current.

5.23 Back Lighting: The ULM-100 allows the user to adjust LCD backlight level to match environment lighting or suit user preferences. Changes can be made in the settings menu and is adjustable from 20% to 100% levels.

5.24 Temperature Monitoring: Ambient temperature is displayed on the home screen in Celsius and on the temperature screen in both Fahrenheit and Celsius. The sensor is located on the front panel next to the alarm LED.

5.25 Meter Power Source Selector: The LCD meter can be powered from the rectifier side or the battery side by using the selector switch. Powering the meter from the rectifier side(default) causes the ULM-100 to completely shutdown during a Low battery voltage disconnect thus reducing battery drain. Powering from the battery side will allow the LCD meter to continue operating even with a an LVD disconnect event.

5.26 Restore to Factory Settings: The ULM-100 comes with default factory settings that will work for most applications. This feature will clear all user setting changes back to factory settings. This is particularly useful in the event the ULM-100 contactor begins cycling. Example: Connect and Disconnect thresholds set too close together. The 'Restore Setting' feature can be activated in the settings menu.

5.3 Battery Circuit Breaker: The Hot side of the battery input goes to a front panel mounted 100 Amp circuit breaker labeled 'BATTERY'. This circuit breaker incorporates auxiliary contacts which will alert the user via the LCD display ('Battery offline') and red 'Alarm' LED, should the breaker trip or be placed in to the OFF position inadvertently.

5.4 Alarm LED: This red LED will illuminate when any of the following conditions occur:

- Battery circuit breaker in OFF position
- LVD Pre-disconnect threshold crossed (see section 5.13 for more info)
- LVD activation- manually or automatically

6.0 Connecting Rectifier Types

The ULM-100 will accept any filtered rectifier input (s) providing total rectifier amperage does not exceed 100 Amps. See Figure 5 and 6 for wiring examples of Newmar Unity Rectifier Shelf (URS) and Power Modules (PM Series).

6.1 Unity Rectifier Shelf (URS): The URS has two sets of output terminals. Both are marked 'OUTPUT/BATTERY'. One set uses a barrier style terminal block with # 6 screw terminals located near the optional UFP-5 fuse panel location and the other is a european style terminal block on the opposite end of URS rear panel which will accommodate up to 8 AWG wire size. The ULM-100 Rectifier Input can be connected to either one of these two sets of output terminals.

UFP-5 Note: If using the optional Unity UFP-5 GMT Fuse Distribution Panel, the UFP-5 Hot & RTN/GND input leads will have to be extended with a pair of 14 AWG wires and crimp butt connectors. Connect extended UFP-5 input wires to the ULM-100 LOAD terminals.

Figure 5: ULM-100 and Unity Rectifier Shelf (URS) with Optional UFP-5 Wiring Diagram

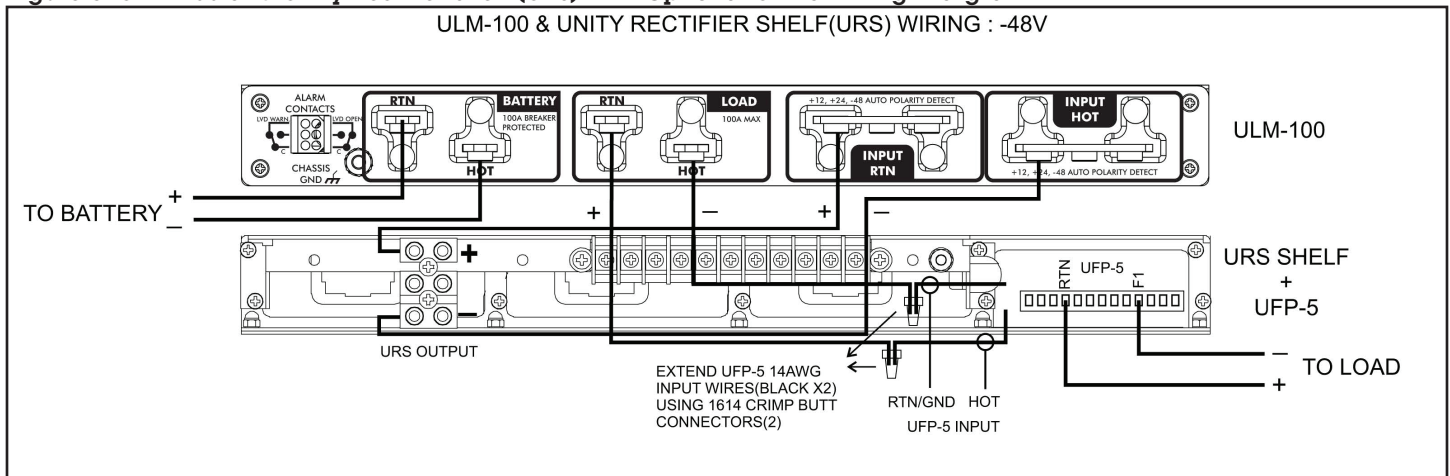

6.2 Power Module (PM Series): One or more Newmar PM Series Power Modules can be connected to the ULM-100 Rectifier Input (100 Amps max. total). Use the 'Vout' or diode isolated terminal when connecting 2 or more PM's in parallel. Figure 6, ULM-100 and Power Module wiring diagram - next page.

Figure 6: ULM-100 and Power Module

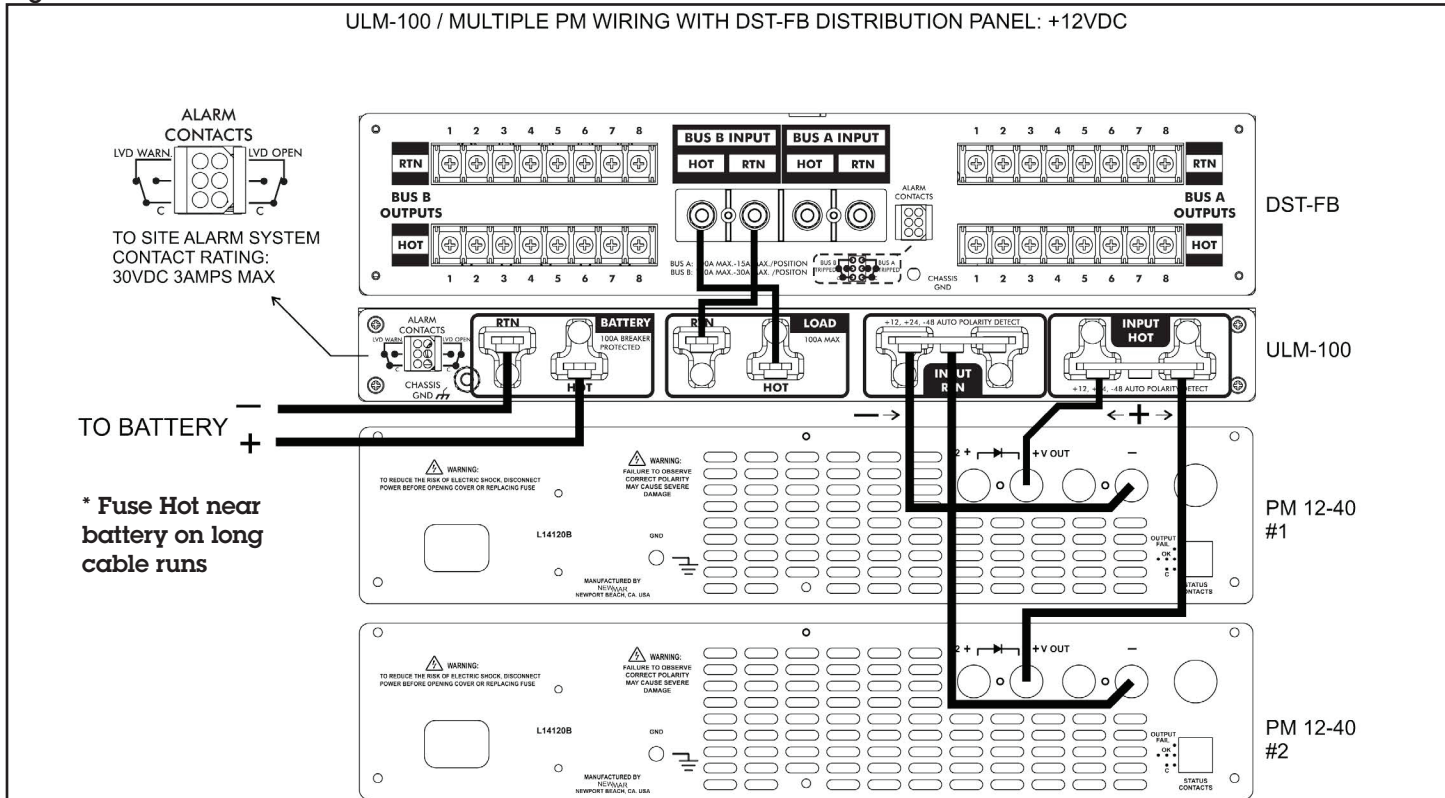

7.0 Troubleshooting

- **Meter Display Errors:** In the event the LCD display gets out of sync with the micro-controller and displays incorrect information, a simple fix is to power cycle the LCD. To power cycle the meter without disconnecting the load: first ensure the rectifiers are on, slide the breaker to OFF position then slide the meter power to 'Battery' then back to 'Rectifier'. This will briefly disconnect power to the meter and allow a safe power cycling and clear the display error. Turn on battery breaker.
- **LVD Stability Issues After Settings Change:** If the LVD contactor cycles frequently after making changes to the LVD default settings, the ULM-100 can be restored to factory settings to aid in troubleshooting (see 5.26 and the menu diagram for details).

8.0 Specifications

Electrical

- Nominal System Voltage:** 12, 24 or 48 VDC
- Voltage Range:** 8 to 65 vdc
- Grounding:** Positive or Negative (polarity insensitive)
- Maximum Continuous Current:** 100 Amps DC
- Battery Breaker:** 100 Amps with handle guard
- Low Voltage Battery Disconnect:** 100 Amp, solid state (FET)
- Factory Default:**

LVD Set Points	12 Volt	24 Volt	48 Volt
Disconnect	10.4V	21.0V	42.0V
Connect	12.0V	24.5	49.0V

Mechanical

- Chassis:** Aluminum with vinyl lamination, black powder coat front panel
- Terminals:** Plated copper. Landings for up to three rectifier inputs, with separate battery & load terminals
- Rack Size:** 19", 1U
- Cooling:** Convection
- Dimensions:** 1.75" H x 19" W x 11" D
- Weight:** 6.25 Lbs.

Environmental

- Operating Temperature range:** 0 to +60°C

Factory Default LVD Pre-Disconnect Alarm Threshold (Adjustable):

System Voltage	12V	24V	48V
LVD Pre- Disconnect	11.2V	22.8V	45.5V

9.0 Outline & Mounting Dimensions

