

# Phase Three

# Three Stage Smart Charger

## Installation/Operation Manual

Models: **PT-24-45W**

**PT-32-25W**



### TABLE OF CONTENTS

Section Topic	Page
QUICK REFERENCE DRAWING.....	2
I) GENERAL INFORMATION.....	3
II) IMPORTANT SAFETY INFORMATION.....	3
III) INSTALLATION.....	4
A) Materials Provided.....	4
B) Location.....	4
C) Mounting.....	4
D) D.C. Output Wiring.....	5
E) A.C. Input Wiring.....	6
F) Multiple Unit Parallel Wiring.....	8
G) Gel-Cell/Lead-Acid Selector Switch.....	9
H) Temperature Compensation Option.....	10
I) Alarm Contacts.....	11
IV) OPERATION.....	11
A) Three Stage Charge Regimen.....	11
B) Time-Out Circuit.....	11
C) Status Indicators.....	11
V) APPLICATION NOTES.....	12
A) Constant Versus Occasional Use.....	12
B) Proper Load Sizing.....	12
C) Operation with Engine.....	12
D) Cooling Fans.....	13
E) Current Limit Circuit.....	13
VI) TROUBLESHOOTING.....	13
VII) SPECIFICATIONS.....	14
VIII) BATTERY CARE TIPS.....	15
IX) REFERENCE APPENDIX.....	16
X) UNIT DIMENSION DRAWING.....	16

## Quick Reference Drawing

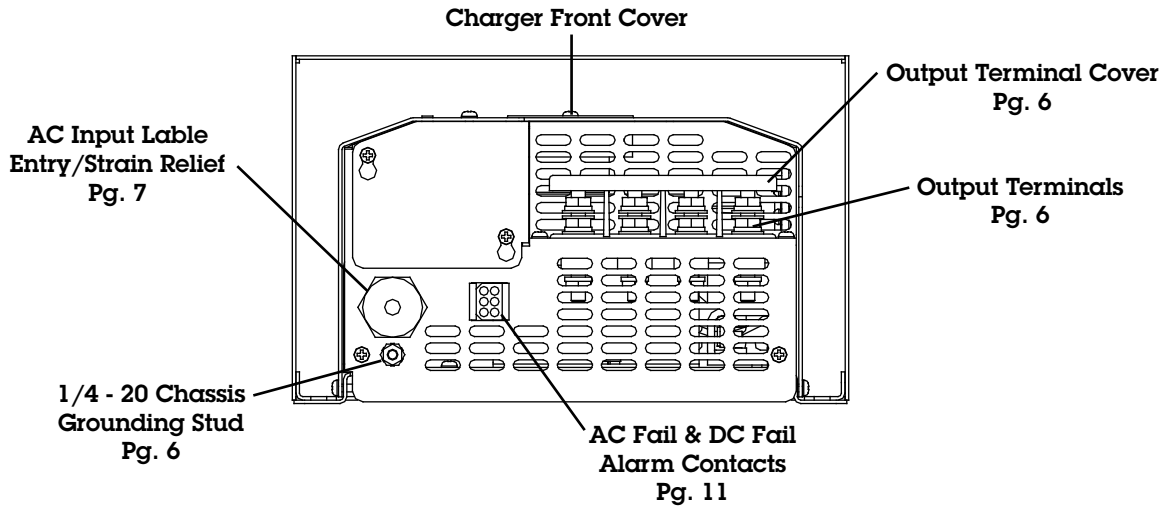
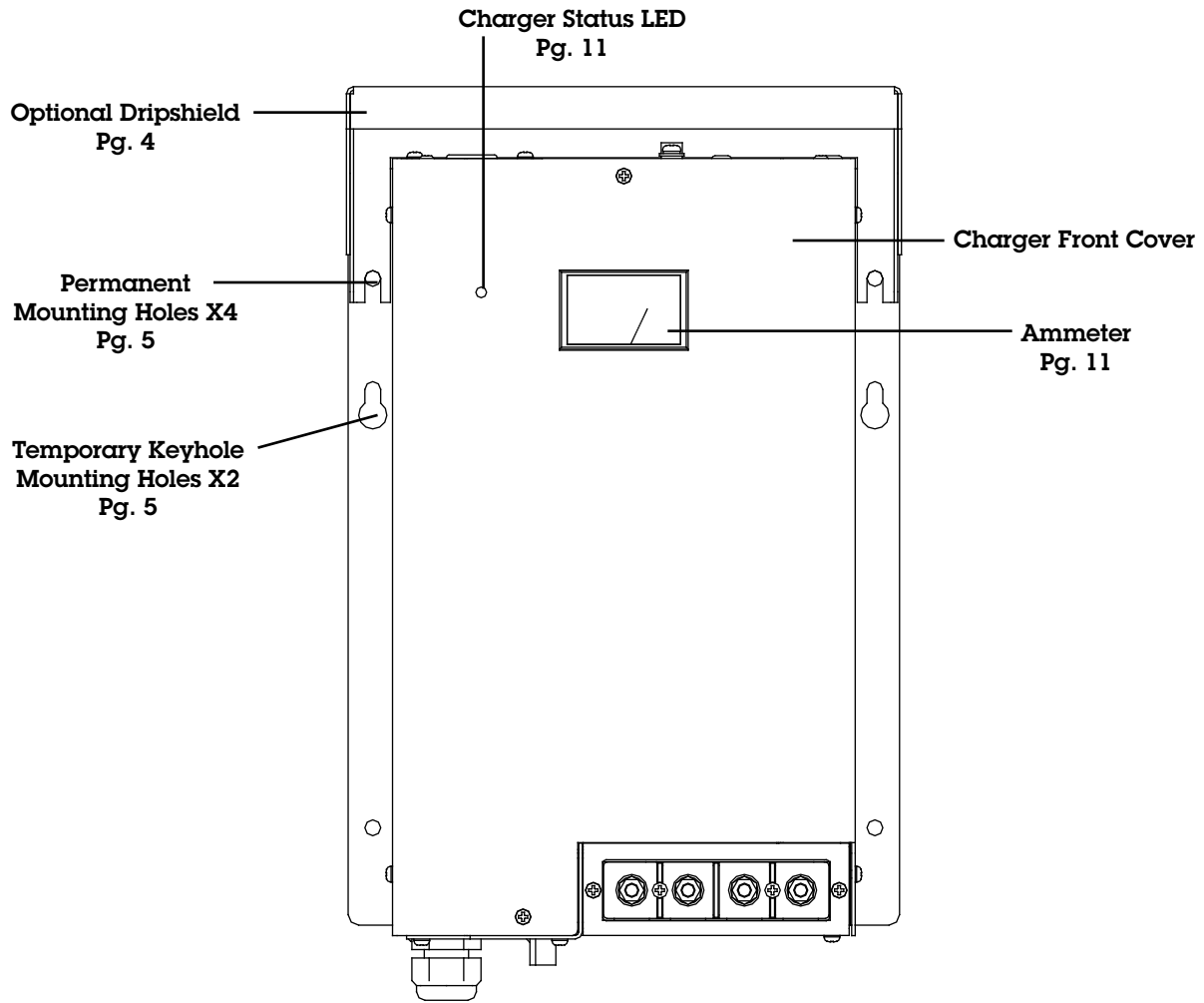

## I) GENERAL INFORMATION

Your Phase Three Series Battery Charger uses the latest microprocessor controlled three stage charging technology to optimize the life and enhance the performance of marine, mobile and fixed site battery systems and is housed in a rugged powder coated stainless steel and aluminum case designed to withstand harsh environmental conditions.

This charger line has been developed in response to demand for increasingly sophisticated charger performance, as the technology of new battery types and applications advances. The Phase Three combines high power performance with adaptability to varied charging requirements and environmental conditions. Batteries are quickly and properly charged and maintained, assuring their long life and optimum performance.

Following is brief listing of some of the more important features/options of your Phase Three Charger. Each is fully detailed later in this manual:

- Micro-processor controlled three stage "smart" charging—bulk, absorption, float—for optimum performance and long life of large battery systems.
- Precision regulated, high power output for rapid rejuvenation of medium-to-large 24 and 32 volt battery systems; maintain batteries at peak voltage, even with high D.C. system loads present.
- Gel-Cell/Flooded lead-acid switch selects optimum charge/float voltages based on battery type.
- Three diode isolated output banks; (ammeter indicates total output current.)
- Optional sensor adjusts output voltage for optimum voltage based on battery temperature.
- Current limiting—prevents damage from overloading.
- L.E.D. and audible indicators show charger status and diagnose shut-down conditions such as Battery Too Hot, Charger Too Hot, Over-Voltage Protection Activated
- High charge time-out circuit prevents overcharge during continuous high amperage demand.
- May be wired in parallel to create higher power systems.
- AC & DC present alarm contacts (Form C) provided
- Built to last—rugged stainless steel and aluminum powder coated case with marinized internal circuitry; drip shield provided.
- Numerous Safety and EMC Compliances; all models carry the CE mark.

In addition, your Phase Three Charger carries a full two year warranty against defects in materials or workmanship from the date of purchase. Careful attention to these instructions should help you to enjoy years of trouble-free service.

## II) IMPORTANT SAFETY INSTRUCTIONS

1. **SAVE THESE INSTRUCTIONS** — This manual contains important safety and operating instructions for the Phase Three Battery Charger.
2. Before using this battery charger, read all instructions and cautionary markings on (1) the battery charger (2) the battery, and (3) any product powered by the battery.
3. **CAUTION** — To reduce the risk of injury, charge only 12 cell (24 volt models) gel-cell or lead-acid rechargeable batteries. Other types of batteries may burst, causing personal injury and damage.
4. Do not expose charger to rain or spray.
5. Use of an attachment not recommended or sold by NEWMAR may result in a risk of fire, electric shock or injury to persons.
6. To reduce the risk of damage to the electric plug and cord (if plugged into an A.C. outlet), pull by plug rather than cord when disconnecting the charger.
7. Make sure the cord is located so that it will not be stepped on, tripped over, or otherwise subjected to damage or stress.
8. An extension cord should not be used. Use of an improper cord could result in a risk of fire and electric shock.
9. Do not operate the charger with a damaged cord or plug; replace them immediately.
10. Do not operate the charger if it has received a sharp blow, been dropped, or otherwise damaged; take it to a qualified serviceman.
11. Do not disassemble the charger; take it to a qualified serviceman when service or repair is necessary. Incorrect reassembly may result in a risk of electric shock and fire.
12. To reduce the risk of electric shock, disconnect the charger from A.C. source before attempting any maintenance or cleaning.

### **WARNING—RISK OF EXPLOSIVE GASES**

1. **WORKING IN THE VICINITY OF A LEAD-ACID BATTERY IS DANGEROUS. BATTERIES GENERATE EXPLOSIVE GASES DURING NORMAL BATTERY OPERATION. FOR THIS REASON, IT IS OF UTMOST IMPORTANCE THAT BEFORE INSTALLING AND USING YOUR CHARGER, YOU READ THIS MANUAL AND FOLLOW THE INSTRUCTIONS EXACTLY.**
2. To reduce the risk of battery explosion, follow these instructions and those published by the battery manufacturer and by the manufacturer of any equipment you intend to use in the vicinity of the battery. Review cautionary markings on these products and on the engine.

## PERSONAL PRECAUTIONS

1. Someone should be within range of your voice or close enough to come to your aid when you work near a lead-acid battery.
2. Have plenty of fresh water and soap nearby in case battery acid contacts skin, clothing or eyes.
3. Wear complete eye protection and clothing protection. Avoid touching your eyes while working near a battery.
4. If battery acid contacts skin or clothing, wash immediately with soap and water. If battery acid enters the eye, immediately flood the eye with running cold water for at least 10 minutes and get medical attention immediately.
5. NEVER smoke or allow a spark or flame in the vicinity of the battery or engine.
6. Be extra cautious to reduce the risk of dropping a metal tool onto the battery. It might spark or short-circuit the battery or other electrical part and cause an explosion.
7. Remove personal metal items such as rings, bracelets, necklaces and watches when working with a lead-acid battery. A lead-acid battery can produce a short-circuit current high enough to weld a ring or the like to metal, causing a severe burn.
8. Use the battery charger for charging gel-cell or flooded lead-acid batteries only. It is not intended to supply power to a low voltage electrical system other than in a starter-motor application. Do not use the charger for charging dry-cell batteries that are commonly used with home appliances. These batteries may burst and cause injury to persons and damage to property.
9. NEVER charge a frozen battery.

## PREPARING TO CHARGE

1. Be sure the area around the battery is well ventilated.
2. Clean battery terminals. Be careful to keep corrosion from coming in contact with eyes.
3. Add distilled water in each cell until battery acid reaches level specified by battery manufacturer. This helps purge excessive gas from cells. Do not overfill. For a battery without cell caps, carefully follow manufacturer's recharging instructions.
4. Study all battery manufacturer's specific precautions such as removing or not removing cell caps while charging and recommended rates of charge.

## GROUNDING AND A.C. POWER CORD CONNECTION

1. The charger should be grounded to reduce the risk of electric shock.

**(For marine applications only) EXTERNAL CONNECTIONS TO THE CHARGER SHALL COMPLY WITH UL RECOMMENDATIONS AND/OR UNITED STATES COAST GUARD ELECTRICAL REGULATIONS (33CFR183, SUB-PART I)**

**(For marine applications only) THE INSTALLATION AND PROTECTION OF VESSEL WIRING ASSOCIATED WITH BATTERY CHARGERS SHALL COMPLY WITH ABYC STANDARDS; E-11) AC & dc ELECTRICAL SYSTEMS ON BOATS, AND A-20) BATTERY CHARGING DEVICES.**

## III) INSTALLATION

### A) Materials Provided

The Phase Three charger is provided completely assembled and ready for installation. Because of numerous installation variables, the installer will need to provide four suitable 1/4" mounting screws/washers, as well as D.C. output wiring and connectors. Proper sizes and gauges for the wire and connectors are noted in section D following. A warranty registration/customer satisfaction card has been included in the packaging. Upon completion of the installation, please fill out this card and return it to the factory. You will be contacted promptly if you have any problems with or questions about your Phase Three charger.

Note: AC & DC Present Alarm Contacts mating connector wire assembly. Contact Newmar and request P/N 773-1210-0. See section III-I for more information.

### B) Location

The charger should be mounted on a wall, bulkhead or other suitable mounting surface as close to the batteries to be charged as possible. Do not mount the charger directly over the batteries as battery fumes may cause excessive corrosion. **WARNING:** The charger is not ignition protected so it must not be located in an area where ignition protected equipment is required. The area should be well ventilated and free from excessive moisture, exhaust manifolds and battery fumes.

Vertical mounting is preferred. However, horizontal mounting is acceptable where absolutely necessary. Do not mount the charger where water, spray or condensation can occur, as this will shorten charger life. It should not be located where there is a possibility of dust or debris being drawn into the unit through the fan. A minimum of 2" clearance around the charger is recommended for proper cooling.

Installation of the drip shield is recommended for areas where moisture or liquids could drip from overhead. The drip shield is mounted using the upper two mounting screws.

If the charger is located in an extreme heat area, such as an unventilated engine room, and maximum operating temperature is exceeded, an automatic thermal shutdown circuit will turn the charger off. Thermal cycling will shorten the life of the charger, so if this condition occurs repeatedly, the charger should be relocated. For optimum performance and longer life the charger should not be located in an area of extreme high temperature.

### C) Mounting

**Important Pre-Installation Notes:** The wiring access port for A.C. input is located on the bottom of the charger. If the factory-installed A.C. cord must be changed for any reason, this should be done before mounting, as access will be difficult afterwards. Also, the drip shield will need to be removed prior to setting the gel/lead acid selector or installing the optional temperature compensation probe. The drip shield is removable with the charger mounted, but if there is limited overhead clearance the installer may wish to accomplish these tasks also, prior to mounting the charger. For information on these installation procedures refer to sections III-E, G and H.

The charger may be mounted on either a metal or non-metal surface\*. You will require four screws (wood or machine screws, depending on mounting surface) with washers, sized for 1/4" holes, to mount the charger, plus two temporary holding screws. Note that, in addition to the four permanent mounting holes in the flanges, there is a hole in each mounting flange which is "keyhole" shaped. This is provided to ease vertical installation.

\*To comply with ABYC D.C. chassis grounding conductor (ABYC A-20), connect a suitable sized wire to the 1/4"-20 chassis grounding stud near AC cable feed through.

Make a mark on the wall or bulkhead where each of the keyhole slots will be located. Then drive a screw about halfway in at each of these marks. Hang the charger onto the bulkhead using the keyhole slots. Doing this will save you from having to support the charger's weight while you are driving in the four permanent mounting screws. Note: The keyhole slots may be used for additional support screws but they are not to be used as permanent mounting points, by themselves.

**IMPORTANT: Although the charger is constructed of materials and in a manner which makes it highly resistive to the corrosive effects of moisture in the environment, the charger is not water-resistant. Do not mount the charger where there is a possibility of water entering the unit. Evidence of water entry into the charger will void the warranty.**

### D) D.C. Output Wiring

Note: Only qualified service personnel should access the output terminals of the charger.

Whether working with existing battery charger output wires or installing new ones, make sure the battery(s) is disconnected from these wires before connecting them to the charger's output terminals.

For a secure installation D.C. output wires must be attached with 1/4" crimp ring lug terminals sized appropriately to fit wire gauges as listed below.

The D.C. wire size table below may be used to determine the correct gauge wire, based on the model you have and the length of the wire run from the charger to the batteries. Once the output wiring has been attached to the charger's output posts, install the clear plastic terminal cover provided with the charger.

#### D.C. Wire Size Table\*:

Model	Distance from Batteries (in feet)		
	10'	15'	20'
	Wire Gauge AWG (mm)		
PT-24-45W	#6 (16mm)	#6 (16mm)	#4 (25mm)
PT-32-25W	#10 (6mm)	#8 (10mm)	#8 (20mm)

\*Based on N.E.C. Minimum Wire Size Chart and ABYC 3% Voltage Drop Chart

Typical D.C. wiring configurations are illustrated in FIGURES 1 and 2 below.

**FIGURE 1: Simple D.C. Wiring (Preferred Method)**

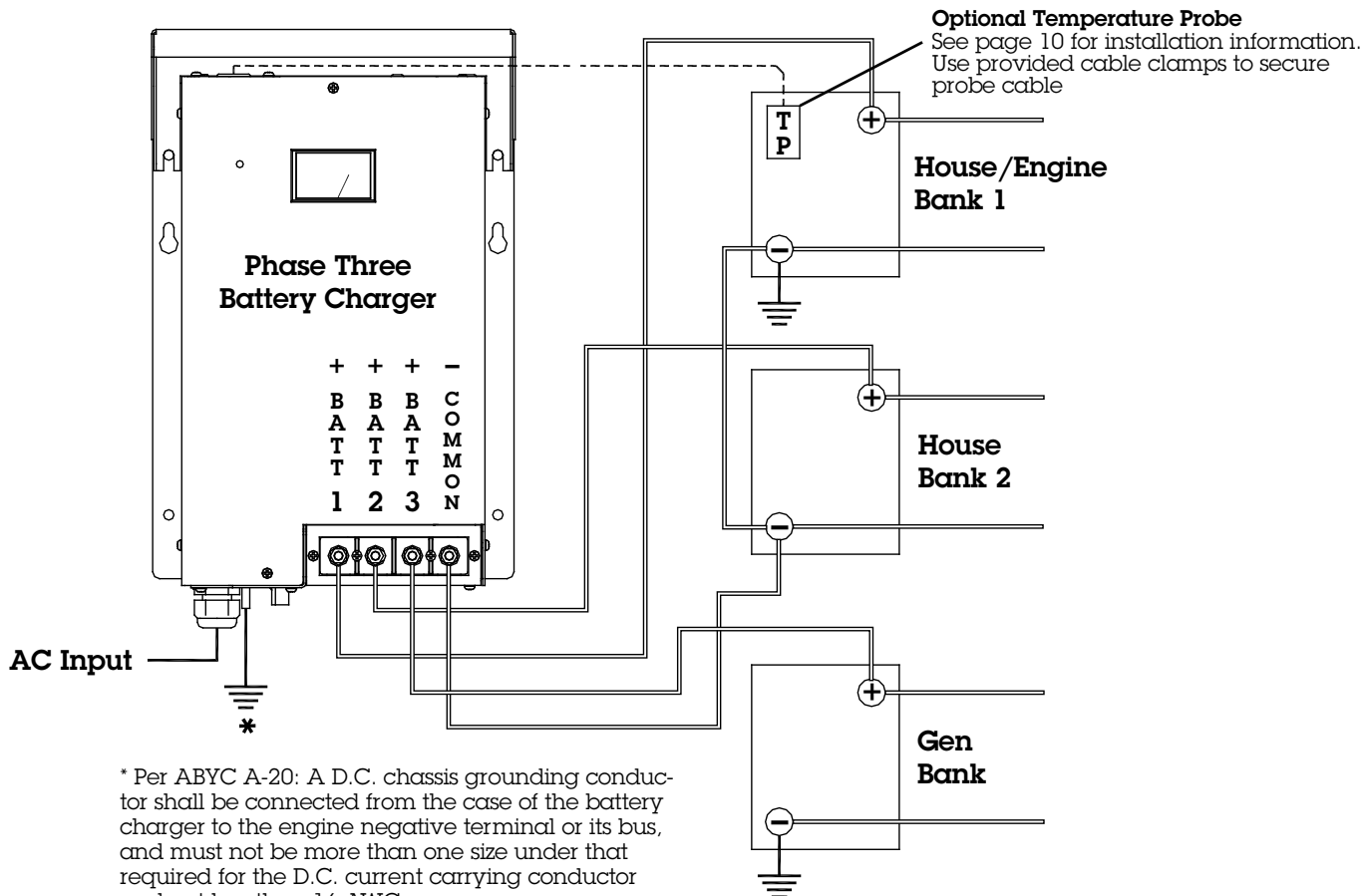

**Note:** This diagram does not illustrate a complete system. Refer to ABYC standards E-11 AC & DC electrical system on boats

**Important: Install fuses at batteries per ABYC recommendations.**

**FIGURE 2: Wiring With Battery Switch**

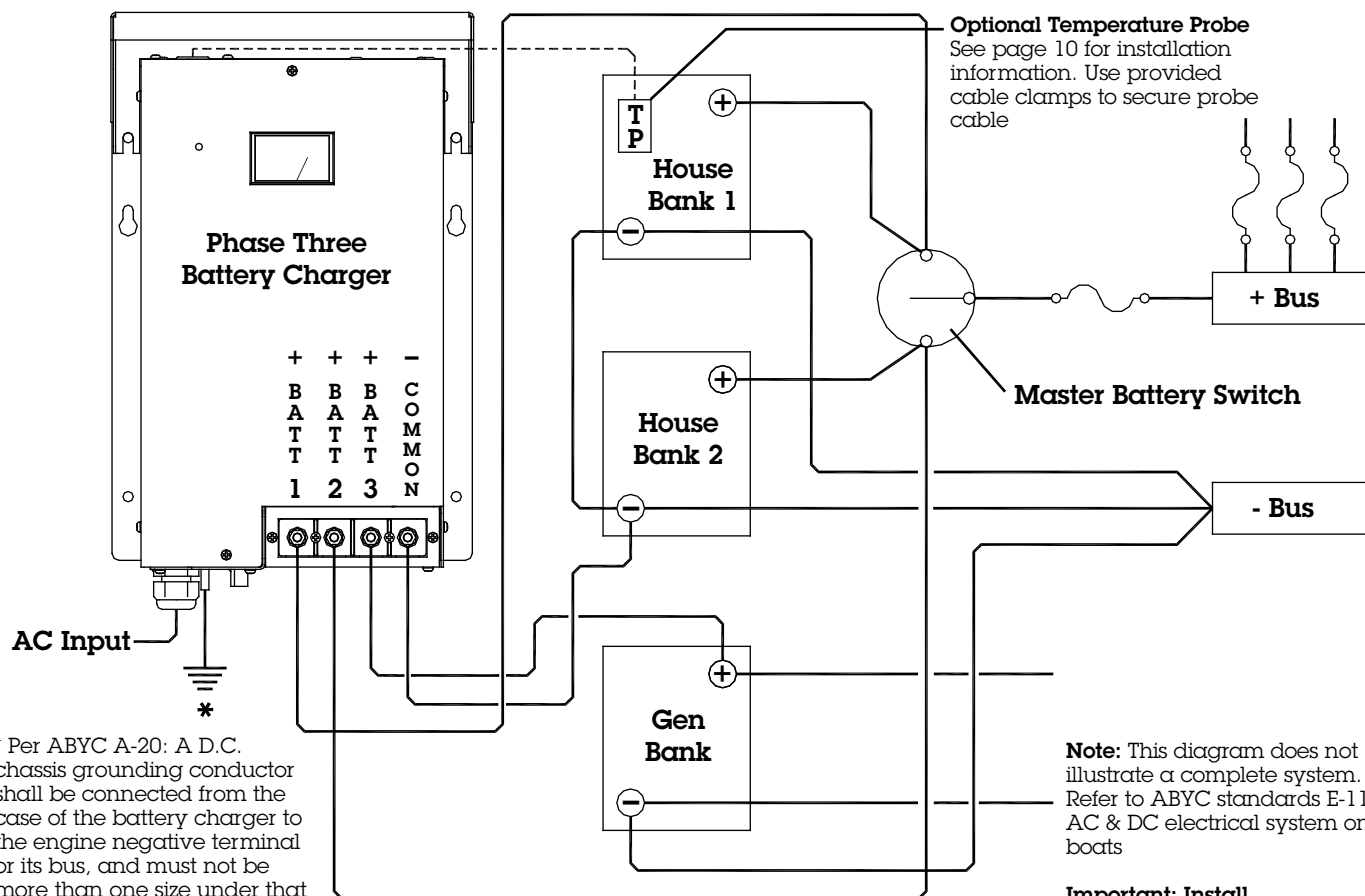

**Optional Temperature Probe**  
See page 10 for installation information. Use provided cable clamps to secure probe cable

**Master Battery Switch**

**Note:** This diagram does not illustrate a complete system. Refer to ABYC standards E-11 AC & DC electrical system on boats

**Important: Install fuses at batteries per ABYC recommendations.**

\* Per ABYC A-20: A D.C. chassis grounding conductor shall be connected from the case of the battery charger to the engine negative terminal or its bus, and must not be more than one size under that required for the D.C. current carrying conductor and not less than 16 AWG

When one or more of the available charger banks is not needed—if, for instance, you have only two battery banks—it is not necessary to jumper the output of that bank onto one of the others. Nor will you get additional charging by running a second wire from the extra bank to your load. The charger is able to deliver its full rated output through a single bank, if necessary.

It is recommended that D.C. wiring from the charger to the batteries be as direct as possible. Line voltage loss and electronic noise interference of sensitive electronics are possible if the charging leads are routed through a central electrical distribution panel. Any elaborate wiring configurations are best left to a qualified electrician.

**CAUTION: ENSURE THAT LEADS ARE PROPERLY FUSED AT THE BATTERY. (REFER TO ABYC RECOMMENDATIONS. SEE REFERENCE APPENDIX AT THE END OF THIS MANUAL FOR ABYC CONTACT INFORMATION.)**

Ensure that your connections are tight and that correct polarity is carefully observed at all times. The battery posts should be free of any rust or corrosion.

**CAUTION: SHORTING THE (+) AND (-) OUTPUTS (WHEN THE CHARGER IS ON) OR REVERSE POLARITY BATTERY CONNECTION (WHETHER OR NOT THE CHARGER IS ON) WILL CAUSE CHARGER FAILURE. THE POSITIVE (+) TERMINAL MUST BE WIRED TO**

**THE POSITIVE POST OF THE BATTERY AND THE NEGATIVE OR COMMON (-) TERMINAL TO THE NEGATIVE POST OF THE BATTERY OR COMMON BUS. DOUBLE-CHECK D.C. WIRING BEFORE ATTACHING TO CHARGER OUTPUT TERMINALS.**

**CAUTION:** Do not attempt to increase battery bank capacity by splitting the output of one of the banks with a diode-type battery isolator. Undercharging may occur on that output bank, as a result.

A note about the D.C. fuse: The internal wiring of the Phase Three charger is protected against dangerous overheating in the event of an internal short, or reverse polarity hook-up, by an internal D.C. fuse. The fuse is not user replaceable. If this fuse blows the unit must be returned to NEWMAR or a qualified electronic technician for repair. (See the TROUBLESHOOTING section of this manual.)

**E) A.C. Input Wiring**

The PT-24-45W is designed to operate on 230V A.C., 50-60 Hz input only. The PT-32-25W is designed to operate on 115 VAC, 50-60 Hz input only. Ensure that the charger is compatible with the available A.C. power.

This model is designed to be hard wired in to the ship's ac system. 16 AWG (1.5mm<sup>2</sup>) wire size is recommended. For A.C. wire runs greater than 20 ft., use 14 AWG (2.5mm<sup>2</sup>) wire size.



A.C. input must be routed through a separate dedicated fuse or circuit breaker on an A.C. distribution panel with proper safety/earth chassis ground in accordance with all applicable local codes and ordinances. Use the table below to determine the proper fuse or circuit breaker value:

**A.C. Fuse/Circuit Breaker Table**

Model	Breaker or Fuse Value
PT-24-45W	10 amp
PT-32-25W	20 amp

**CAUTION PT-24-45W:** If A.C. input is derived from a source consisting of two HOT leads (phase-to-phase or L<sub>1</sub> & L<sub>2</sub> 230V A.C. input voltage), an external fuse or circuit breaker must be used to

protect the unfused (formerly NEUTRAL, now HOT) lead. AC Input hard-wiring procedure (refer to Figure 3):

- 1) Loosen (do not remove) the two screws on the bottom front of the charger which holds the A.C. input wiring access plate in place. Remove the cover plate to expose the A.C. input terminals as shown in figure 3.
- 2) With a narrow blade (1/8") flat tip screwdriver, loosen the compression screw terminals on the right side of the A.C. input terminal block. Do not loosen the factory-wired terminals.
- 3) Loosen the compression nut on the A.C. input cable strain relief and slip the nut over the A.C. input cable.

**FIGURE 3: TP Probe/AC Input Wiring**

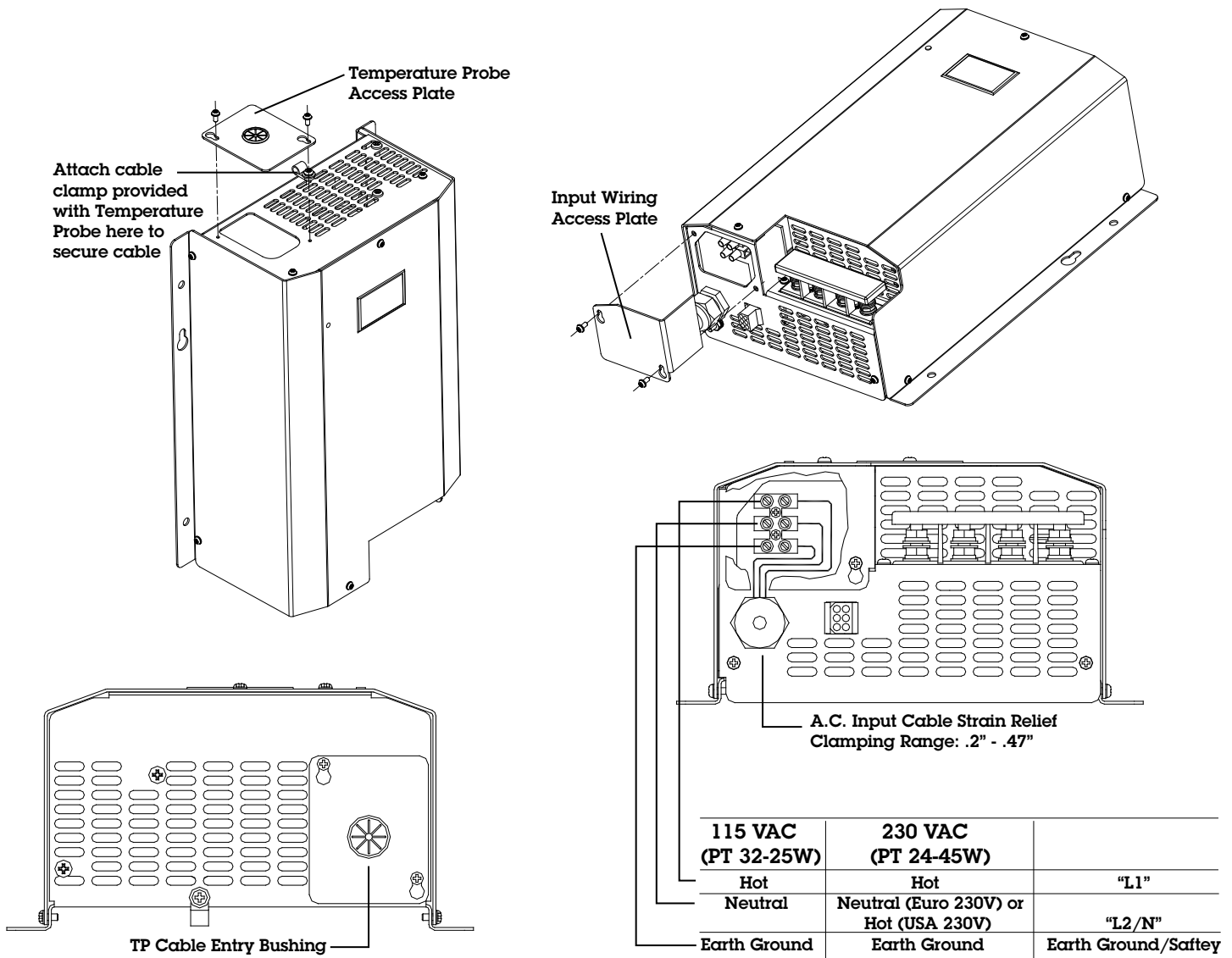

4) Cut away the outer jacket of the new three-wire A.C. input cable so that individual wire leads are about 2" long. Strip about 1/4" of insulation off the ends of each wire and feed the cord through the input cable strain relief.

5) Insert each A.C. input wire into the appropriate L1, L2/N or EARTH GROUND terminal and tighten securely.

6) Tighten the compression nut on the input cable strain relief. Replace the A.C. input wiring access plate and tighten the two screws.

(In marine applications) All charger wiring should be installed in accordance with UL, U.S. Coast Guard and/or A.B.Y.C. regulations and recommendations, as well as all relevant local codes. See section VIII) REFERENCE APPENDIX for sources.

A note about the A.C. input fuse: The A.C. input of your charger is protected by an input fuse which is located inside the unit. Due to the current limiting characteristic of the charger, it is highly unlikely that this fuse will blow unless there is some other malfunction within the charger. This fuse is not user-replaceable. Replacement of the input fuse must be performed by a qualified service person. (See TROUBLESHOOTING section for further information.)

## F) Multiple Unit Parallel Wiring

Multiple Phase Three chargers may be wired in parallel, if necessary. They are diode protected against feedback from other units and current limiting will prevent overloading, see figure 4.

Two reasons for paralleling chargers are:

- 1) To increase charging current of an existing system
- 2) Redundancy (in the event one charger fails, system can be powered by redundant charger)

Parallel wiring recommendations:

- 1) Use the same wire size on both chargers and wire both chargers directly to the battery posts. If practical, use the same wire length on output of each charger. This will help the chargers to share current when they are both in the same charging stage.
- 2) If temperature compensation option is used, a separate sensor must be provided for each charger (see section III-H Temperature Compensation Option) and the sensor ends connected to the same batteries.
- 3) Make sure both chargers are set for the same battery type (see section III-G, Gel-Cell/Lead Acid Selector).

Note: Under certain line and load conditions, it is normal for paralleled chargers to output different amounts of current. It is also normal when ac power is connected or interrupted to see the chargers in different charge modes (Float, Absorption or Bulk.)

**FIGURE 4: Parallel Wiring for Increased Charging Current**

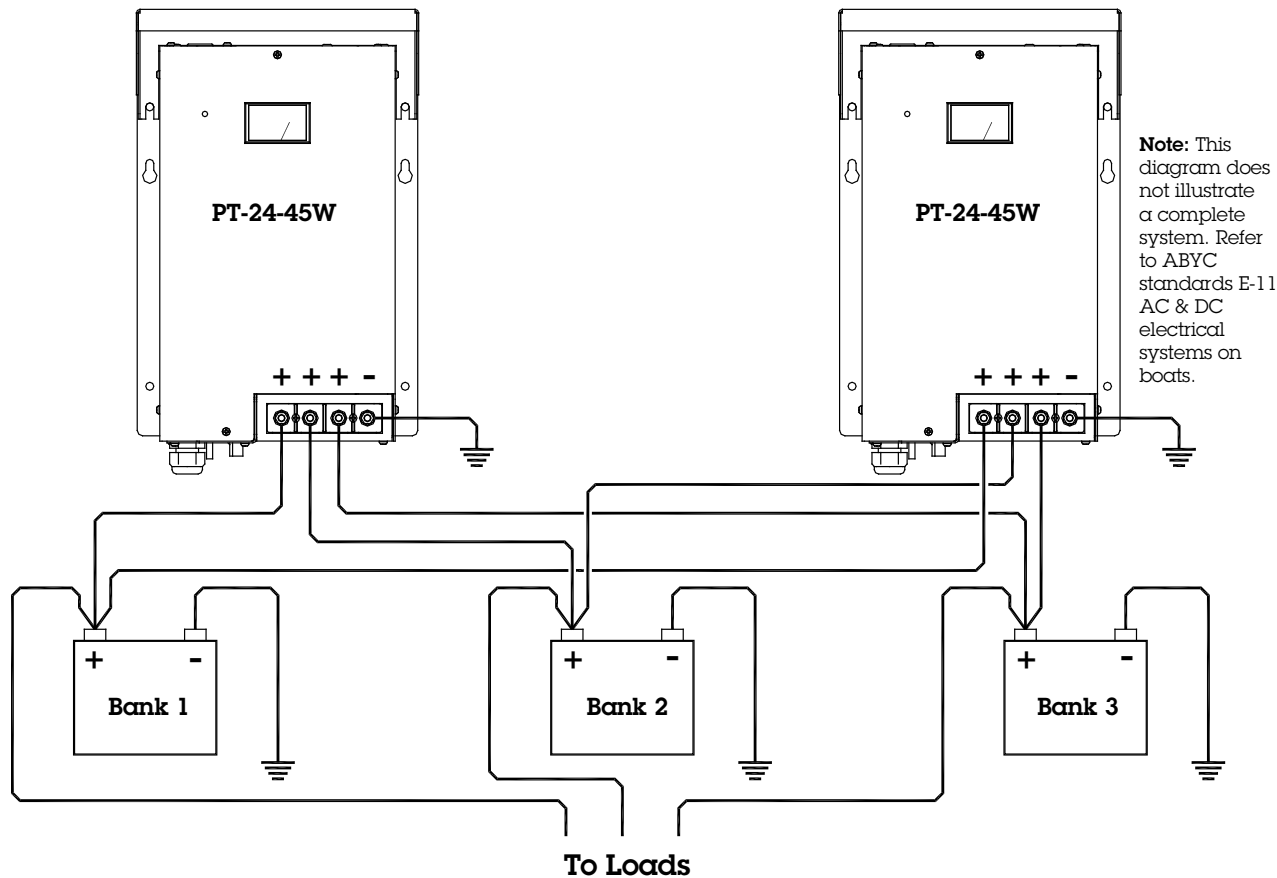



## G) Gel-Cell/Lead Acid Selector

### Checking or Setting the Selector

The ideal charge/float regimen has been programmed into the Phase Three Charger for either sealed gel-cell or flooded lead-acid batteries depending on the selector position. The selector has been factory set in the lead-acid position. In order to check or change the gel/lead-acid selector setting, proceed as follows (see Figures 5 & 6):

- 1) Ensure A.C. power to the charger is shut off.
- 2) Locate the access plate on top of the charger and loosen the two Phillips head screws (DO NOT REMOVE SCREWS.) Remove access plate.
- 3) Locate the gray circular switch which is recessed into the internal black module. (Note: There may be a self-adhesive black

plastic cover over this switch, remove cover.) This switch has 16 selector positions: 0, 1, 2, 3, 4, 5, 6, 7, 8, A, B, C, D, E, F. Positions 0 thru 7 correspond to Flooded/Lead Acid, positions 8 thru F correspond to Gel-Cell/VRLA

4) Use a flat blade screwdriver to rotate the switch into the correct position, with either "F" or "7" showing as illustrated below:

5) If installing the optional Temperature Compensation Sensor, proceed with that installation (described in section H following).

6) Reinstall the access plate and tighten the two Phillips head screws.

**FIGURE 5: Gel-Cell/Lead Acid Selector**

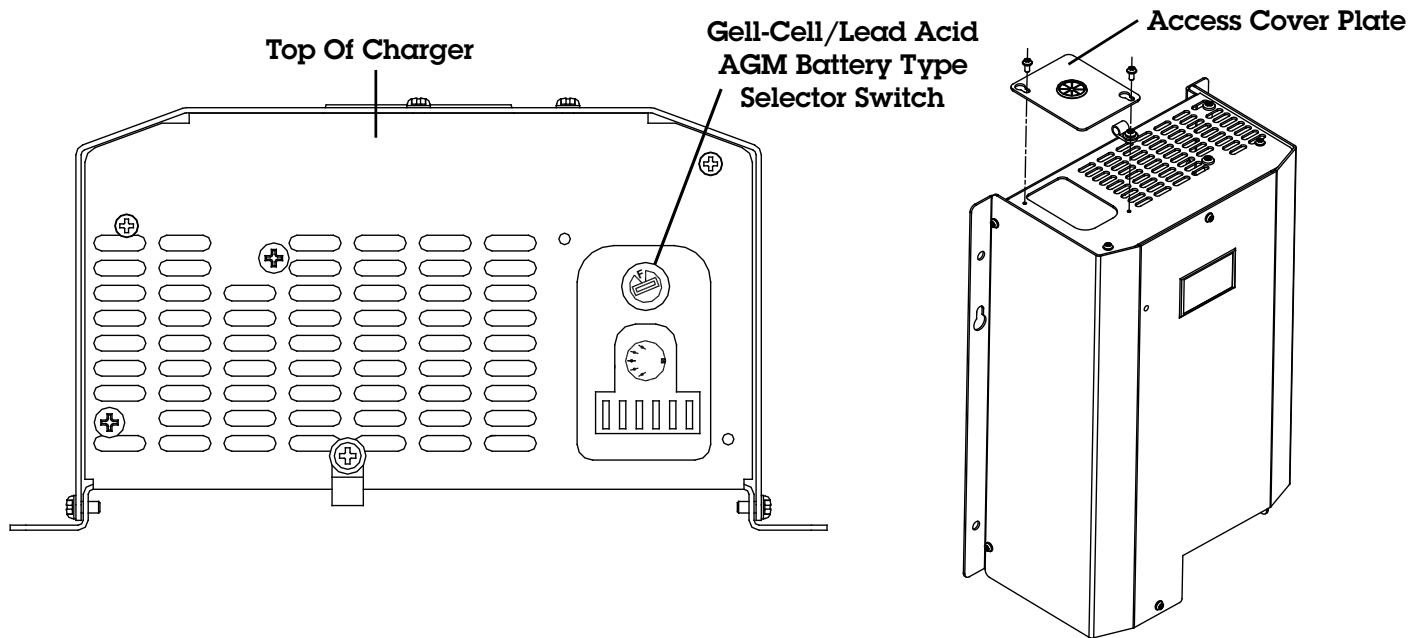

**FIGURE 6: Gel-Cell/Lead-Acid Selector Positions**

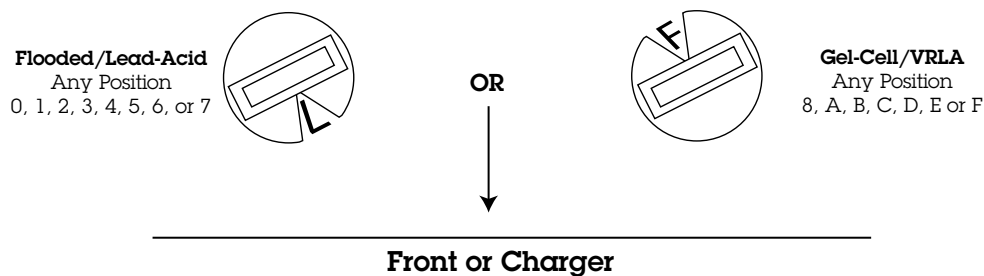

## Gel/Lead-Acid Selector Function

According to battery manufacturers, the ideal charge regimen for gel-cell and wet or flooded lead acid batteries differs somewhat.

The gelled electrolyte in a sealed battery may be lost or damaged by high voltage and, once lost, cannot be replaced as it can with a wet lead acid battery. Manufacturers of gel-cells usually recommend an ideal charge voltage which is slightly lower for a gel-cell than a lead acid battery.

However, when the charger is in the float voltage mode over lengthier periods of time, gelled electrolyte in a sealed battery is not susceptible to evaporation, as is the non-immobilized electrolyte of a wet lead acid battery. This evaporation can be accelerated by the applied voltage. Consequently, the ideal float voltage is slightly higher for a gel-cell than a lead acid battery.

Some batteries are available which do not conform to conventional descriptions as "gel-cell" or "lead-acid". If you are unsure about your battery type, consult the manufacturer and use the battery type selector setting which most closely conforms to the recommended voltages. See the SPECIFICATIONS section for the actual preset charge and float voltages for each battery type and charger model.

## H) Temperature Compensation Option

### Installing the Probe

The optional Temperature Compensation Probe (available from NEWMAR, model TP) is provided with 25' of cable, with the probe at one end and a keyed five-pin plug at the other. Installation of the probe proceeds as follows:

- 1) Ensure A.C. power to the charger is shut off. The charger will go into a shutdown mode if the temperature sensor is installed when power is on.
- 2) If the drip shield is installed, remove it.
- 3) Refer to Figure 5. Locate the access plate on top of the PT-24-45W and loosen the two Phillips head screws (DO NOT REMOVE SCREWS.) Remove the access plate.
- 4) Locate the five-pin keyed receptacle which is recessed in the black internal module. (Note: There may be a self-adhesive black plastic cover approx. 1 1/2" x 1 1/2" square, over this receptacle, remove cover.)

5) Route the temp. sensor end of the TP through the black bushing on the access plate. Insert the 5 pin connector end of the TP firmly into the receptacle. Replace the access plate and tighten the two Phillips head screws.

6) It is recommended that the cable running to the battery be secured with the provided cable clamps to prevent the plug from accidentally being dislodged. One cable clamp tie point (10-32 Phillips head screw with washers) has been provided to secure the cable as it exits the top of the charger.

7) The probe itself should be mounted on the inside of the battery box, or more ideally, mounted directly onto one of the batteries using a clamp or a small amount of silicon-type adhesive.

Important note: When wiring multiple units in parallel and using the temperature compensation option, you must use a separate probe for each charger, and the probes must be mounted close together in the same battery box or on the same battery for proper operation.

## Temperature Compensation Probe Function

Because low battery temperature increases resistance to charging and high battery temperature reduces impedance, requiring a lower charge voltage, the ideal charging voltage will vary depending on the temperature of the battery's environment when it is being charged.

If a charger has a fixed output voltage which is ideal at, say 77° F, that same output may cause a battery charged in a consistently high temperature environment to be overcharged, resulting in excessive loss of electrolyte. Conversely, if the batteries are located in a consistently cool environment, they may be chronically undercharged, resulting in sulfation of the battery plates. Either of these two conditions will shorten battery life.

Therefore, the Phase Three charger is designed to utilize an optional probe which provides automatic temperature compensation. The function of the probe is to signal the charger to fine tune its output voltage so that it is properly optimized for the temperature of the battery or battery environment. The adjustment rate is approximately -5 mV per cell per °C.

To give some idea of the effect of the temperature compensation probe, the chart below lists the charge/float output voltages of the charger when no sensor is installed (or when batteries are at 25° C) and some sample charger output voltages at colder or hotter battery temperatures with the probe installed:

Battery Temp° C	24 Volt				32 Volt			
	Lead Acid/AGM		GEL		Lead Acid/AGM		GEL	
	Float	Absorption	Float	Absorption	Float	Absorption	Float	Absorption
10	28.0	29.6	28.4	29.2	37.3	39.5	37.9	38.9
20	27.4	29.0	27.8	28.6	36.5	38.7	37.1	38.1
25	27.1	28.7	27.5	28.3	36.1	38.3	36.7	37.7
30*	26.8	28.4	27.2	28.0	35.7	37.9	36.3	37.3
40	26.2	27.8	26.6	27.4	34.9	37.1	35.5	36.5
50	25.6	27.2	26.0	26.8	34.1	36.3	34.7	35.7

\* Output voltages with no Temperature Probe installed



## D) Alarm Contacts

The charger provides one set each of dry alarm contacts: A.C. Fail and D.C. Fail. These can be used to activate a light or buzzer if connected to a supervisory alarm system. Contacts are rated: 30 VDC @ 1 Amp, 110 VDC @ 0.3 Amps. For mating connector wire assembly, contact Newmar and request P/N 773-1210-0.

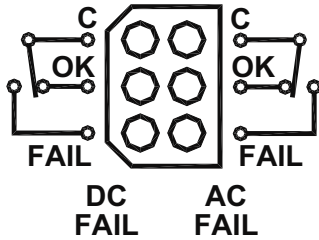

## IV) OPERATION

### A) Three Stage Charge Regimen

The Phase Three Battery Charger features the three stage charge regimen which is widely recommended by battery manufacturers for allowing the fastest possible recharge time without loss of batteries' electrolyte (gel or liquid) which may be caused by sustained charging at higher voltages.

This three stage regimen is initiated each time A.C. is first applied, when drained batteries are most likely to be encountered, and proceeds slowly or quickly through each stage depending on the battery's relative state of charge. The L.E.D. Status Indicator on the front panel indicates which stage the charger is in.

The regimen proceeds as follows:

**1) Bulk Charge - Status Indicator: Glowing Yellow.** When batteries are significantly discharged the charger responds initially by delivering a high amount of D.C. current, at or near the charger's maximum rated output, in order to rapidly replenish them. It is during this stage that charging current is maintained at a high level as battery voltage increases. Bulk charging continues until battery voltage reaches the "charge" voltage level (where batteries are at about 75-80% of capacity). A power limit circuit prevents charger overload during this maximum output stage. Note: During this bulk phase the charger is in a "constant power" mode; therefore, as output current increases, output voltage decreases, and vice versa. Full output voltage is achieved and maintained only when the charger switches to the absorption stage.

**2) Absorption Charge - Status Indicator: Glowing Green.** During this second stage of the charge cycle, battery voltage is maintained at the "charge" voltage level. Output current begins to taper off as the battery plates become saturated. Charge voltage is maintained until the current sensing circuit detects that output current has tapered to about 5-15 % of charger rating\*. At this point the batteries are at about 95 % of full charge and the charger switches to the third and final stage of the charge cycle.

\* Note: The absorption phase may also be ended by the time-out circuit. See section B following for an explanation of the purpose and functioning of the time-out circuit.

**3) Float Charge - Status Indicator: Blinking Green.** For extended battery life the Phase Three then automatically switches to a

lower float voltage level. This float charge keeps batteries at peak condition without overcharging. The charger may be left in this stage for lengthy periods of time without attention (though periodic checks of electrolyte level in flooded batteries is recommended). It is not necessary or recommended to shut the charger off when this stage is reached.

A typical three stage charging cycle is illustrated in FIGURE 7.

**FIGURE 7: Typical Charger Output Graph (into battery without load)**

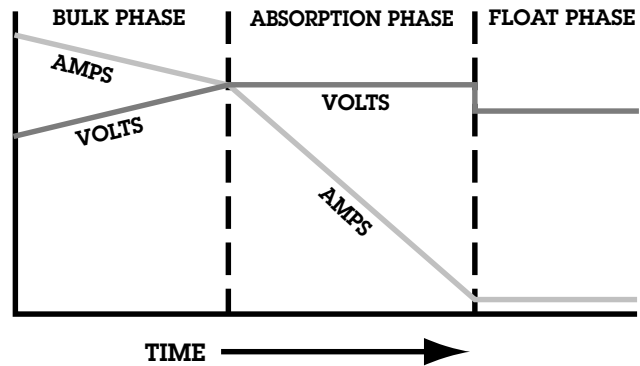

\* Approximately 10 hours maximum at factory setting.

Note: If a load is applied during the absorption phase, the charger may revert to the bulk phase depending on the total current draw. When the charger switches to the float phase, it will remain in that phase regardless of current draw. The charger is still able to deliver full output current when in the float phase. To re-initialize the three stage process shut the charger off momentarily, then back on again.

### B) Time-Out Circuit

Batteries have a tendency to lose their electrolyte and may be damaged if they are maintained for long periods of time in the elevated voltage of the absorption phase. Therefore, the Phase Three Charger employs a special high charge rate time-out circuit. This circuit is initialized each time A.C. is first applied to the charger and runs for a pre-set interval of approximately 10 hours before forcing the charger to go into the float (lower voltage) mode.

If the current demand of the batteries/load falls below 5-15 percent of the charger's output capacity prior to the circuit timing-out, the charger will switch to the float mode and will remain in that mode until the charger is shut off and restarted, although it will continue to respond to any current demand within charger rating.

If current demand continues to remain above the 5-15 percent-of-capacity threshold, the charger will remain in the bulk or absorption phase (depending on total current draw) until it is forced into the float mode by the time-out circuit.

### C) Status Indicators

The Phase Three Charger is equipped with an L.E.D. (located to the left of the output ammeter) which signals each of the three normal operational stages (described in detail above), and which also, in combination with an audible tone indicator, provides warning and diagnostics of abnormal conditions which result in charger

shutdown (described below). Note: If the Status Indicator L.E.D. is not lit, this probably indicates either disconnection from A.C. power (check A.C. input) or thermal cycling (see Note in item 1, below).

## NORMAL OPERATING MODE

The three indications in the Normal Operating Mode are as follows: Glowing Yellow, Glowing Green and Blinking Green. These correspond respectively with the Bulk, Absorption and Float charger stages, which are fully described in the previous section, A) Three Stage Charge Regimen.

## SHUTDOWN MODE/SELF-RESET ADVISORY MODE

There are three warning/diagnostic indications to alert the user to a condition in which the charger is currently shut down. In each case, a flashing red L.E.D. is accompanied by an audible "beep". Additionally, there are two diagnostic indications to advise that the charger shut itself down but has since resumed operation. The warning/diagnostic indications are as follows:

**1) One Red Flash-Beep:** Cause: The charger's internal module is too hot and the charger output has shut off. This may be due to high ambient temperature, insufficient clearance around the charger resulting in poor ventilation, or debris causing a blockage of the fan intake vent at the bottom of the charger. Corrective Action: Turn charger off at the AC source. Verify proper clearance, remove debris and, if necessary, relocate charger to a cooler location. Turn charger back on to resume normal operation and L.E.D. indications. Note: Even if no corrective action is taken, when the charger cools sufficiently by itself then it will automatically return to service and the L.E.D. indicator will begin to display a series of single yellow flashes (see item 5 below). If this type of thermal cycling is noted, and continues after all of the above corrective actions are taken, please contact the factory.

*Note: Overheating will normally result in the above indication. However, there is a second thermal switch mounted to an internal diode heat sink and, in certain cases of extreme overheating, this switch may temporarily shut off A.C. input to the charger entirely. In this case the L.E.D. will be extinguished and there will be no audible indication, but the charger will probably be warm to the touch.*

**2) Two Red Flash-Beeps:** Cause: The Over Voltage Protection (OVP) circuit has been activated and charger output has shut down. The purpose of this circuit is to protect batteries and load against damaging high output voltage in the event of an internal malfunction or component failure. This circuit may also be activated if the charger is putting out high current into heavily discharged batteries and the batteries are abruptly switched off of the output (called a load dump). The abrupt removal can cause an output voltage spike which triggers this circuit. Corrective Action: Verify proper connection of charger output terminals to batteries. Turn charger off for a few seconds, then back on again to resume normal operation and L.E.D. indications.

**3) Three Red Flash-Beeps:** Cause: Battery temperature is too hot and the charger is shut off. (Note: The optional thermal probe must be installed for this diagnostic function to operate. See section III-H for complete information.) This may be due to extremely high ambient temperature in the battery environment, such as when installed in a hot engine room. It may also be due to a shorted cell in one of the batteries, causing "thermal runaway". Corrective Action: Turn charger off. Relocate batteries to a cooler area or improve ventilation and/or check for a shorted cell in each battery—refer to BATTERY CARE TIPS section for procedure or refer

to battery manufacturer for recommendations. Turn charger back on to resume normal operation and L.E.D. indications. *Note: This shutdown/warning will also occur if the temperature sensor is plugged in or unplugged while the charger is in operation. If this is the case, make sure the plug is properly inserted and shut the charger off and then back on; normal operation will resume.*

If the battery cools sufficiently for safe charger operation, the charger will automatically return to service, however the L.E.D. indicator will begin to display a series of three yellow flashes (see item 5 below).

**4) One Yellow Flash:** Cause: Charger was too hot and shut down but has cooled sufficiently and has returned to service. Corrective Action: Refer to Item 1 of this list of indications.

**5) Three Yellow Flashes:** Cause: Battery was too hot but has cooled sufficiently and charger has returned to service. Corrective Action: Refer to Item 3 of this list of indications.

In each of the above cases, if corrective action has been taken and the charger has been shut off and turned back on, but does not resume normal operation, refer to the TROUBLESHOOTING section or contact the factory for assistance.

## V) APPLICATION NOTES

### A) Constant Versus Occasional Use

In general, it is recommended that the charger be left connected continuously to A.C. power so that it will be in operation whenever A.C. is available. This will maintain batteries at peak voltage and will automatically compensate for the natural self-discharge of the battery system. When a load is applied to the battery system the charger's output will automatically increase to supply the current which would otherwise draw battery voltage down. Repeatedly allowing batteries to become completely discharged before recharging will greatly shorten their life. Leaving the charger on continuously will prevent this.

While the output regulation of the charger will minimize battery gassing and water loss, monthly checks of the electrolyte level (for wet lead acid batteries) are still strongly recommended. Some water loss is an inevitable aspect of the charging process, and maintaining the correct electrolyte level in your batteries is the most important thing you can do to assure their maximum performance and long life.

### B) Proper Load Sizing

The Phase Three Charger is rated for continuous duty. While the charger cannot be damaged by overloads that exceed its continuous rating, excessive load demands may draw battery voltage down faster than the charger can resupply it. If battery voltage continues to drop, check to ensure that your average D.C. loads are not exceeding the charger's rated output at full (float) voltage. (Refer to SPECIFICATIONS section for Max Current ratings.) If loads exceed this rating, you may wish to consider adding another charger in parallel to provide sufficient power for your requirements. (See section III-F) Multiple Unit Parallel Wiring.)

### C) Operation With Engine

It is perfectly acceptable to allow the charger to remain on when the engine is started and while it is running. The current

limit feature of the Phase Three Charger will protect against any damage due to the high current demands of engine cranking. Output diodes will prevent any back-feed of current into the charger from the alternator while the engine runs.

As the alternator starts to charge the battery, the charger output will decrease. When the battery voltage exceeds the rated output voltage of the charger it will cease charging and will have no output as long as the batteries are in this high state of charge. If the battery voltage should drop below the charger's rated output voltage it will automatically return to service.

#### D) Cooling Fans

To maximize the life of the internal components and to allow continuous operation at full rating, the Phase Three charger employs multiple integral cooling fans. Both variable speed and thermally cycling fans are used. Whenever load and/or ambient temperature cause a significant rise in the internal temperature, these fans will adjust automatically or cycle on and off, as necessary, to cool components, extending their operating life. Under no load and cool ambient temperature no fan movement may be detected, but this does not indicate fan failure. Increased load and/or rising ambient temperature should cause fan activation.

No lubrication or maintenance is required. Simply ensure that there is a free flow of air around the charger (approximately 2 or more inches around all sides) and that there is no debris clogging the ventilation perforations in the charger chassis.

#### E) Current Limit Circuit

The Phase Three Charger is self-limiting and protected against overloads by a fast-acting current limit circuit which automatically reduces output voltage to protect the charger when a current demand is encountered which exceeds the charger's power limit rating. This may be due to extremely discharged batteries which are beyond the recommended amp-hour rating, or a large D.C. load being applied while batteries are heavily discharged, for instance. (See SPECIFICATIONS section for maximum power limited amps and recommended battery capacity ratings.) If a check of the output voltage is taken when the charger is under this extreme current draw, it may measure only a fraction of normal output voltage. This is a normal function of the current limit circuit. To check proper charger operation, simply remove the overload and observe that normal output voltage has automatically resumed.

**Important Note: The current limit circuit will not protect the charger against a dead short across the (+) and (-) output terminals when the charger is turned on. Charger failure will result.**

## VI) TROUBLESHOOTING

**Note 1:** The Phase Three charger incorporates a self-contained A.C. to D.C. conversion module. This module houses several automatic protection circuits, as well as the A.C. input and D.C. output fuses to protect internal wiring. Under most circumstances these fuses will fail only if the charger has an internal fault. They are not user-replaceable. The following section deals primarily with the charger's protection features (some requiring manual charger reset; others auto-resetting). If an apparent charger fault cannot be corrected using any of the recommendations in this section, the charger should be returned to the factory or place of purchase for inspection and repair or replacement.

**Note 2:** Certain charger or battery problems are self-diagnosing with the Phase Three charger. For any shutdown condition which has caused the charger's Status Indicator to signal with one or more Red L.E.D. "Flash/Beeps" or Yellow Flashes, refer to section IV-C Status Indicators to diagnose and resolve the problem.

Condition	Possible Cause	Solution
A) Status Indicator show charger has shifted into float stage but batteries are not coming up to full charge.	1) High-rate time-out circuit has activated, but extremely discharged batteries requiring longer recharge time.  2) Charger limiting its output due to overload.  3) Charger output is not properly connected to batteries.	1) Turn off all D.C. loads and allow charger 24-48 hours to recharge batteries. See section IV-B for explanation of time-out circuit.  2) Reduce D.C. load.  3) Refer to D.C. wiring section of this manual and verify compliance with instructions and diagrams
B) Charger continues to charge at 3 amps or more – does not taper back into charge	1) D.C. load drawing current from batteries (not a problem condition).  2) Bad cell in one of the batteries to which charger is connected.	1) To confirm charger will output minimal amperage to fully charged batteries, shut off all D.C. loads or turn off main battery switch to D.C. distribution panel.  2) Check for shorted cell in all flooded type batteries – see Battery Care Tips section. Refer to manufacturer for testing maintenance-free batteries.

Condition	Possible Cause	Solution
C) Front panel status indicator is not lit and there is no indication of charger output.	1) Charger is not receiving A.C. input voltage or is connected to incorrect A.C. voltage  2) Extreme overheating of charger has caused thermal switch to temporarily shut off A.C. input.  3) Reverse polarity connection or direct short across output terminals has caused failure.	1) Confirm charger model is compatible with 115V or 230V A.C. voltage being applied. Check for proper input voltage with A.C. voltmeter. Check input wiring connections.  2) If charger is warm to the touch while the Status Indicator is extinguished, refer to section IV-C, item 1, which explains the two types of thermal shutdown indications and solutions.  3) Refer to factory contact information below.
D) Charger repeatedly trips input circuit breaker with no batteries connected.	Internal Short	Refer to factory contact information below.
E) High output voltage measured across output terminals.	Batteries not connected to charger	Check for tight connection of charging leads to batteries.

If a problem with your charger persists after you have applied the above-outlined solutions, or if you have any questions about the installation and proper operation of your charger, please contact NEWMAR's Technical Services Manager:

Phone: 714-751-0488 — From the hours of 7:00 A.M. to 4:30 P.M. weekdays, P.S.T.  
 Fax: 714-957-1621 — Anytime  
 E-Mail: techservice@newmarpower.com — Anytime

We will respond no later than the following business day and are always happy to consult with you to resolve any problem you may have. If it appears the charger must be returned to the factory for repair we will issue a Return Materials Authorization at that time.

## VII) SPECIFICATIONS

Model	Input		Output			Battery Capacity (Amp-Hour)	Weight	
	VAC±10% 50-60 Hz	Max Amps	Max Amps @ P.L.*	Max Amps @ F.V.**	Banks		Lbs.	Kg.
PT-24-45W	230	8	45	38	3	90-450	12.2	5.6
PT-32-25W	115	15	27	24	3	50-300	12.2	5.6

\* P.L. = Maximum amps at Power Limit

\*\* F.V. = Maximum amps at Full (Float) Voltage—See OUTPUT VOLTAGES below

### CASE SIZE

Inches	Centimeters
<b>H x W x D</b>	<b>H x W x D</b>
13.8 x 9.8 x 5.0	35.0 x 24.9 x 12.7

Add 1.27" (3.2 cm) to height and 1.1" (2.8 cm) to depth with drip shield installed.

### OUTPUT VOLTAGES

(without Temperature Compensation option installed):

Setting	24 VOLT MODEL		32 VOLT MODEL	
	Charge	Float	Charge	Float
	@ .5 amp load		@ .5 amp load	
Gel-Cell	28.0 V D.C.	27.2 V D.C.	37.3 V D.C.	36.2V D.C.
Lead Acid	28.4 V D.C.	26.8 V D.C.	37.8V D.C.	35.7V D.C.

**TEMPERATURE COMPENSATION:** - 5 mV per cell per ° C

**PROTECTION FEATURES**

- Input Fuse
- Output Fuse
- Self-Limiting (Current Limited)
- Over Voltage Protection  
(Latching circuit; resets when A.C. is cycled off and on)
- Cooling Fans
- Automatic Thermal Shutdown

**COMPLIANCES**

Safety: EN60335-1

EMC: IEC 1000-4-2, -4  
EN55014

Carries the CE Mark

**VIII) BATTERY CARE TIPS**

Regular maintenance and proper care will assure you reliable service from the most depended upon and sometimes most neglected items, your batteries and battery charger. NEWMAR battery chargers are designed to keep your batteries fully charged but your batteries also need proper regular maintenance to provide a maximum life of service.

**ALWAYS READ AND FOLLOW THE BATTERY MANUFACTURER'S INSTRUCTIONS**

**Battery Installation**

Batteries must be securely mounted to prevent them from falling over when the vehicle or boat is in motion. A loose battery can do serious damage. Batteries should be mounted in a battery box to contain any acid spill. Batteries give off a certain amount of hydrogen gas when they are charging. When concentrated, this gas is highly explosive. Therefore make sure they are in an accessible place with adequate ventilation for any hydrogen gas discharge.

**Cleaning Batteries**

Dirt and electrolyte salts can build up on the top of your batteries. This accumulation conducts electricity stored in the battery and can cause the battery to discharge by itself. Therefore, at least twice a year, it is a good idea to disconnect the battery cables and scrub the battery with a baking soda solution. Rinse with fresh water and dry with a clean cloth.

You may wish to purchase a set of terminal post corrosion prevention rings. These are alkali-saturated felt rings that slip over the battery post to reduce corrosion. Do not apply grease to any part of the battery terminals, but you may use an occasional light spray of silicone lubricant.

**Routine Checks and Maintenance**

Batteries should periodically be "exercised" (slowly discharged and then recharged) to keep them in top condition. New batteries may need to be exercised before they will be capable of their full rating.

If your batteries are not the sealed type, distilled water should be added to them whenever needed. The electrolyte should cover the plates by about 1/2", allowing a small air space at the top. Do not fill the cells up to the filler cap as this could cause the battery to sputter out electrolyte when it is being charged. Only distilled water should be used never plain tap water. Tap water contains chemicals and elements that can alter the properties of the electrolyte, including specific gravity. Some chemicals may also create an insulating coating on the battery plates which will retard current flow.

The rate that water is lost by the battery is dependent on several factors; battery condition, ambient temperature, battery use, charge voltage, etc. It is normal for batteries which are not maintenance-free to require topping off about once a month.

A battery's state of charge may be monitored by checking the specific gravity or by open circuit voltage. You may use the following table to evaluate the condition of your batteries:

**Battery Condition Table**

Specific Gravity Measured by Hydrometer	Open Circuit Voltage		State of Discharge @ 80° F
	24 Volt System	32 Volt System	
1.265	25.2 or more	33.5 or mre	Fully Charged
1.225	24.8	33.0	25% Discharged
1.190	24.4	32.5	50% Discharged
1.155	24.0	32.0	75% Discharged
1.120	23.4 or less	31.1 or less	100% Discharged

*\* Note: Wait at least 5 minutes after charging or discharging before checking specific gravity or open circuit voltage. The battery's voltage needs to stabilize in order to get an accurate reading.*

*\* Note: Wait at least 5 minutes after charging or discharging before checking specific gravity or open circuit voltage. The battery's voltage needs to stabilize in order to get an accurate reading.*

**Troubleshooting Your Battery System**

If your battery will not accept or hold a charge, one of the following conditions may exist:

- 1. A BAD BATTERY.** You may have a battery with an open or shorted cell, a battery without any "life" left. Check by charging the battery until all cells have a specific gravity of 1.225 or greater at 80° F. If you are unable to obtain 1.225 in each cell, replace the battery. For maintenance-free or gel-cell batteries consult the manufacturer.



**2. A BAD BATTERY CHARGER.** If the battery open circuit voltage is low and/or the hydrometer indicates your batteries are low, the battery charger should be providing current to the batteries. If it is not, check A.C. input and check to see that you have charging voltage on the output with no battery attached. Note: You will not get an accurate voltage reading on the output of the charger with no batteries attached. This is checked merely to ensure that you do not have an open circuit on the output.

The battery charger has a thermal cutout switch to turn the charger off if it is overheating. If you suspect this is the case, refer to the information regarding charger location in the Installation section and cooling fans in the Application Notes section.

**3. ELECTRICAL LEAKAGE.** You may have a previously unsuspected source of current drain from the battery. To check for a leakage of this sort, disconnect the battery ground cable and connect an ammeter between the negative battery post and ground. If you have a reading over .1 amp, there is a source of current drain from the batteries which must be located and removed.

**IX) REFERENCE APPENDIX**

**X) UNIT DIMENSION DRAWING**

\* For more information about boat wiring to conform to U.S. Coast Guard regulations, write:

Superintendent of Documents

Request : 33 CFR 183 Subpart I  
Government Printing Office  
Washington, DC 20402

\* For information about American Boat and Yacht Council recommendations for boat wiring, write to:

American Boat and Yacht Council  
3069 Soloman's Island Road  
Edgewater, MD 21037

Request: Standards and Recommended Practices for Small Craft.  
AC & DC systems: Section E11  
A-20: Battery Charging Devices

\* For additional installation instructions, refer to: ANSI NFPA 302

