

# Unity Rectifier System

## Models:

**UR48-3:** 48 Volt, 3 Amp Rectifier

**UR24-6:** 24 Volt, 6 Amp Rectifier

**URS:** Rectifier Shelf (3 rectifier bays plus 1 fuse panel bay)

**UFP-5:** GMT Fuse Distribution Panel (optional)

## INSTALLATION / OPERATION MANUAL

### I) OVERVIEW

The Unity Rectifier System comprises a low profile 1.75" (1 RU) shelf which accommodates up to three 150 watt, -48 or +24 volt hot-swap rectifiers, plus an optional distribution panel which contains five individually fuse-protected circuits. The system is scalable/adaptable for N, N+1 or N+2 configurations.

The optional power distribution module employs industry standard GMT fuses, configured with alarm contacts and a front panel "BLOWN FUSE" LED indicator.

Front panel test points and voltage adjustment pot are provided for fine-tuning output to the requirements of sensitive loads and to optimize load sharing.

Form C status contacts enable remote alarms for the rectifiers and fuse distribution circuits. Front panel OK/FAIL LED's allow monitoring status of each rectifier individually.

The Unity system is engineered for compatibility with NEWMAR's Battery Module/Shelf system to create a DC UPS with scalable battery capacity to meet reserve run time requirements.

### II) SHELF INSTALLATION

#### A) Mounting

The Unity Shelf is shipped from the factory with brackets installed for flush-mounting in a 19" rack. They may be repositioned for 6" forward mounting if the installation requires. Brackets for 23" racks are attached (for shipment purposes only) facing inward from the 6" forward mounting position. These must be removed and reinstalled properly (if using a 23" rack) or discarded.

The Unity Rectifiers are front-to-back forced-air cooled, therefore no empty rack positions are necessary either above or below the unit to maintain proper operating temperature.

#### B) AC Input

The Unity Shelf/Rectifiers accept 85-264 VAC, 47-63 Hz input. No input switch resetting or jumper reconfiguration is needed for either 115 or 230 VAC applications. The shelf is provided with a 7.5' power cord with plug suitable for standard 115 VAC 15 amp outlets. If plug replacement is required for a 230 VAC outlet, observe color coding as follows:

M-UR4824  
As of April 2009

1

Black..... AC Hot (fused inside individual rectifiers)  
 White..... AC Neutral  
 Green..... AC Ground (safety, earth)

*230 VAC Application Note: When the shelf/rectifiers are powered by 230 VAC consisting of two hot legs (line-to-line) they should both be over-current protected using a double pole circuit breaker.*

**C) DC Output/Battery Connection Points**

*Note: Refer to the Unity Shelf Rear Panel Diagram below for wiring DC Output/Battery connections, as well as alarm wiring and optional fuse distribution panel wiring.*

DC output/battery connection for all three rectifier positions is paralleled at the "+" and "-" positions of both the large white nylon and smaller black plastic output terminal strips on the rear of the shelf. (Note: The clear cover on the black terminal strip is simply snapped on and off for access.) The recommended connection point depends on wire size as indicated in the wire size chart and shelf diagram below. Output may be taken directly from these terminals or loads may be wired to fuse-protected output terminals on the rear of the optional UFP-5 Fuse Panel. (Refer to Fuse Panel Installation, section IV following.)

**Output Wire Size Chart**

<u>Load</u>	<u>Minimum Wire Size per N.E.C.</u>
0-6 Amps	18 AWG
7-10 Amps	16 AWG
11-20 Amps	14 AWG

**Unity Shelf Rear Panel Diagram**

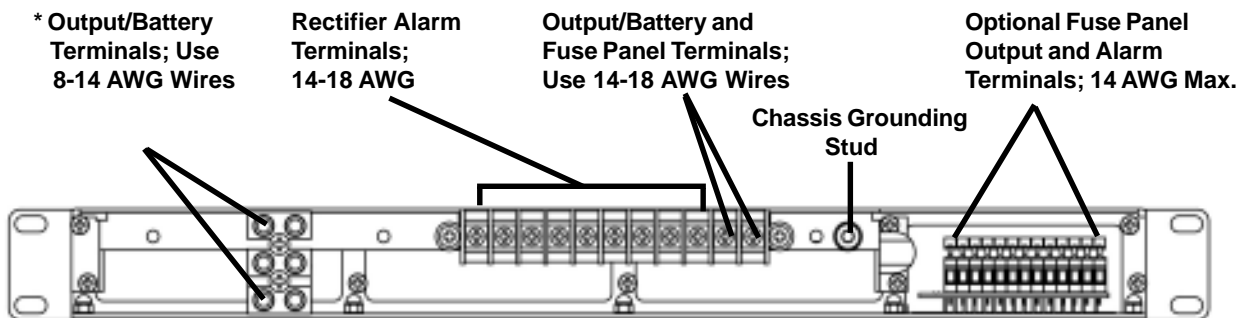

**\* We recommend installing a fuse or circuit breaker on Battery Hot.**

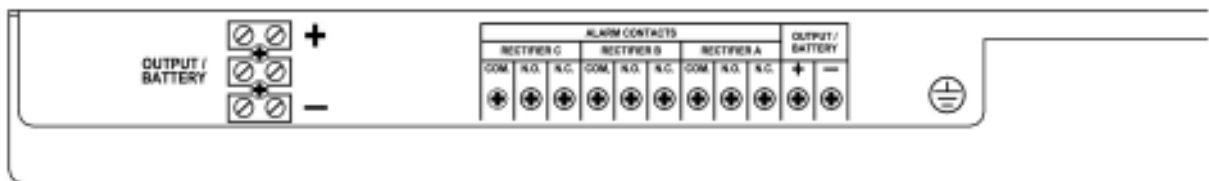

Rear Panel enlarged to identify Output/Battery and Rectifier Alarm terminal positions; See section IV-A for enlargement of optional fuse panel terminal block

### III) RECTIFIER INSTALLATION/OPERATION

#### A) Installation

The Unity Shelf accepts either model UR48-3 (-48 VDC) or UR24-6 (+24 VDC) Rectifier Modules. The system is designed for module installation while the shelf is "hot", therefore the modules may be removed or inserted while AC is being applied to the shelf and loads are being powered. **CAUTION:** Ensure that the power switch on the front panel of the rectifier is in the OFF position prior to inserting or removing the module.

Slide the rectifier into the open RECTIFIER A position and secure it using the front panel captive retaining screws. Two blank panels for covering unused bays are factory installed in the RECTIFIER B and C positions (plus one covering the optional fuse panel position), and are easily removed for installing additional rectifiers. These should be left in place in any unused bay(s) to optimize proper air flow from the fans through the shelf, as well as helping to strengthen it.

#### B) Output Indications

The output LED on the rectifier front panel indicates status as follows:

Green = OUTPUT VOLTAGE PRESENT

Red = OUTPUT VOLTAGE NOT PRESENT

*Note 1:* The red failure-indicating LED requires power from a parallel, functioning rectifier or from a battery wired to the output bus terminals. If only a single rectifier without battery is used, this LED will be extinguished in the event of failure.

*Note 2:* This LED may also illuminate if the rectifier output voltage has been adjusted significantly below that of the parallel rectifier(s). All rectifiers should be adjusted to identical output voltages—see section C following.

Yellow = OUTPUT VOLTAGE MISADJUSTED

If the output voltage misadjustment mentioned in *Note 2* above falls between .65 and .75 VDC below the parallel rectifier this LED may glow *yellow*. The module is still operating but it is sharing very little of the load.

No LED (Fans Running) = SEVERE OVERLOAD

Unit is in current limit. This circuit is self resetting as soon as the load is sufficiently reduced or additional rectifiers are brought on line to handle the load.

No LED (Fans Not Running) = NO AC INPUT to the shelf or the individual module, and no battery connected to the output. If extinguished, check first to ensure that the module is properly inserted and that the power switch is on.

#### C) Output Voltage Adjustment

The factory output voltage settings and user adjustment range are as follows:

	<b><u>Factory Setting</u></b>	<b><u>Adjustment Range</u></b>
<b>UR48-3:</b>	54.4 VDC	42-56 VDC
<b>UR24-6:</b>	27.2 VDC	21-28 VDC

Front panel test points are provided for calibrating output voltage with an external voltmeter. Adjustment is made at the front panel potentiometer.

#### D) Current Sharing Adjustment Procedure

When two or more rectifiers are employed, the following procedure is recommended to optimize droop current sharing between them:

- 1) Connect a digital voltmeter to the front panel test points of the first rectifier to be calibrated.
- 2) Shut off the other rectifier(s) in the shelf with the front panel power switch. If any batteries have been attached to the output, disconnect them.
- 3) Apply a minimum one amp load to the output bus, but no more than 75% of the rectifier's output rating.
- 4) Adjust the front panel potentiometer with a small slot screwdriver until the desired bus voltage is achieved.
- 5) Shut off the first rectifier, turn on the next, and adjust the potentiometer until it reads the same as in step 4. As long as the voltage is within 1 to 2/10ths of a volt, current sharing will be adequate.
- 6) Repeat steps 4 and 5 with the third rectifier (if one has been installed).
- 7) Reattach the batteries (if applicable), turn on all rectifiers, and apply the normal system load.

Output voltage may drift over time due to semiconductor tolerances, therefore periodic checks and readjustment may be required to optimize current sharing.

#### IV) FUSE PANEL INSTALLATION (OPTIONAL COMPONENT)

##### A) Installation/Wiring

The UFP-5 Fuse panel is provided with one 5 amp GMT fuse and a fuse-puller. Additional fuses are available from NEWMAR in 1, 3, 5 and 10 amp ratings.

*IMPORTANT:* Prior to installing the panel, turn it over and check the position of the jumper on the printed circuit board. As shipped from the factory it is in the 48V position. For 24 volt installations move the jumper to the 24V position. Slide the panel into the shelf while feeding the input/output wires through the rear, then secure it with the front-panel retaining screws.

The input wires are labeled "HOT" and "RTN/GND" (return/ground). These must be attached to the Output/Battery "+" and "-" positions on the black terminal strip as follows:

**-48 volt systems (positive ground):**

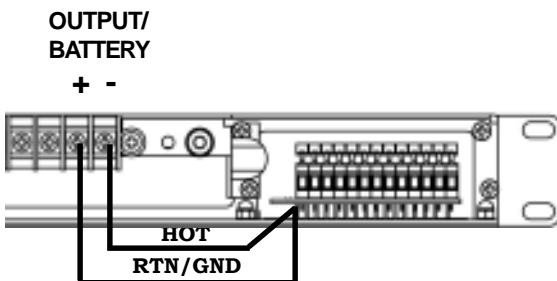

**+24 volt systems (negative ground):**

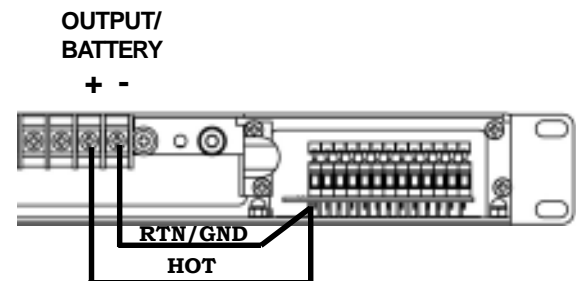

4

Insert an appropriately sized GMT fuse for each load at the front panel fuseholder (positions are labeled F1-F5).

*Note: The maximum fuse value for any single position on the fuse panel is 10 amps. The UFP is rated for a total of 20 amps maximum.*

Wire each load at the hot (also labeled F1-F5) and return/ground (labeled RTN) rear terminals. Maximum wire size is 14 AWG, and each should be stripped to about 1/4". To install the wire, use a small-tip screwdriver to push the lever at the top of the terminal toward the front of the shelf and down (as illustrated on the following page), then insert the wire and release the lever to capture it.

**Installing Wires in the Fuse Panel Terminal Block - Side View**

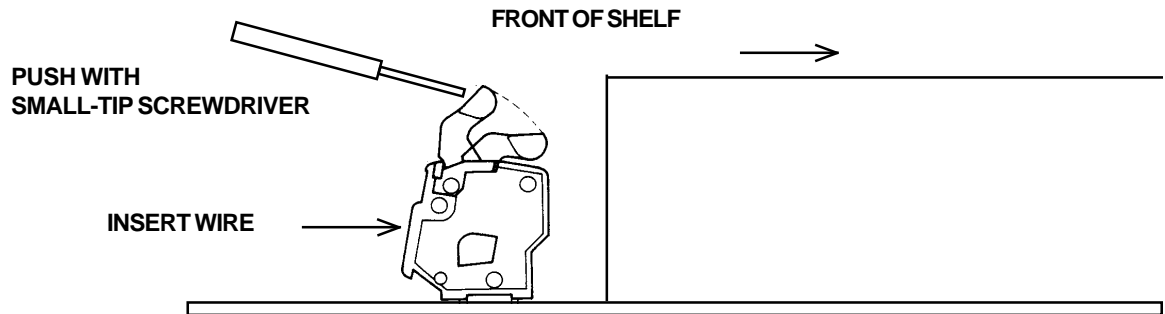

**Fuse Panel Terminal Block - Rear View (enlarged to identify terminal positions)**

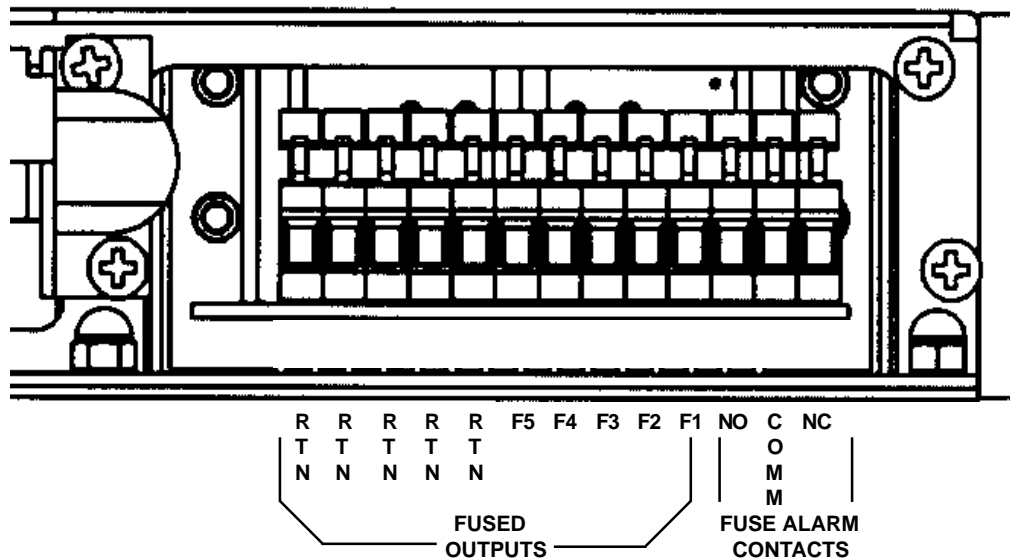

**B) Fuse Replacement**

In the event of a blown fuse the red LED on the front panel will be illuminated. At the same time a spring-loaded colored tab will be released and visible at the top of the fuse to indicate which GMT fuse has blown.

The provided fuse-puller will simplify removal. Contact NEWMAR or your equipment supplier for replacement fuses.

## V) ALARM CONTACTS

### A) Rectifier Alarm Wiring

Form C alarm contacts are provided for each rectifier, individually, on the black terminal strips on the rear of the shelf. The alarm will be activated if AC power is interrupted to the shelf or if the rectifier fails. For instance, if the internal fan fails and the resultant high temperature causes the thermal switch to shut the rectifier off, the alarm will be activated.

Labels behind the terminal strips identify the "C" (Common), "NO", (Normally Open) and "NC" (Normally Closed) contact positions. Rectifier "A", "B" and "C" refers to the position of the rectifiers from left to right as viewed from the front of the shelf.

#### Rectifier Summary Alarm Wiring for Contact Closure

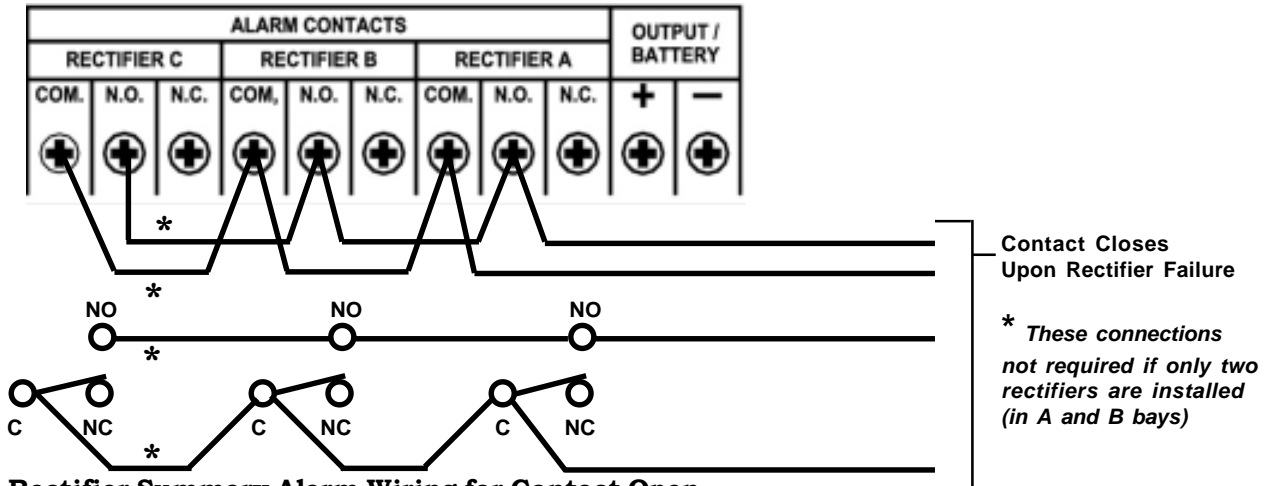

#### Rectifier Summary Alarm Wiring for Contact Open

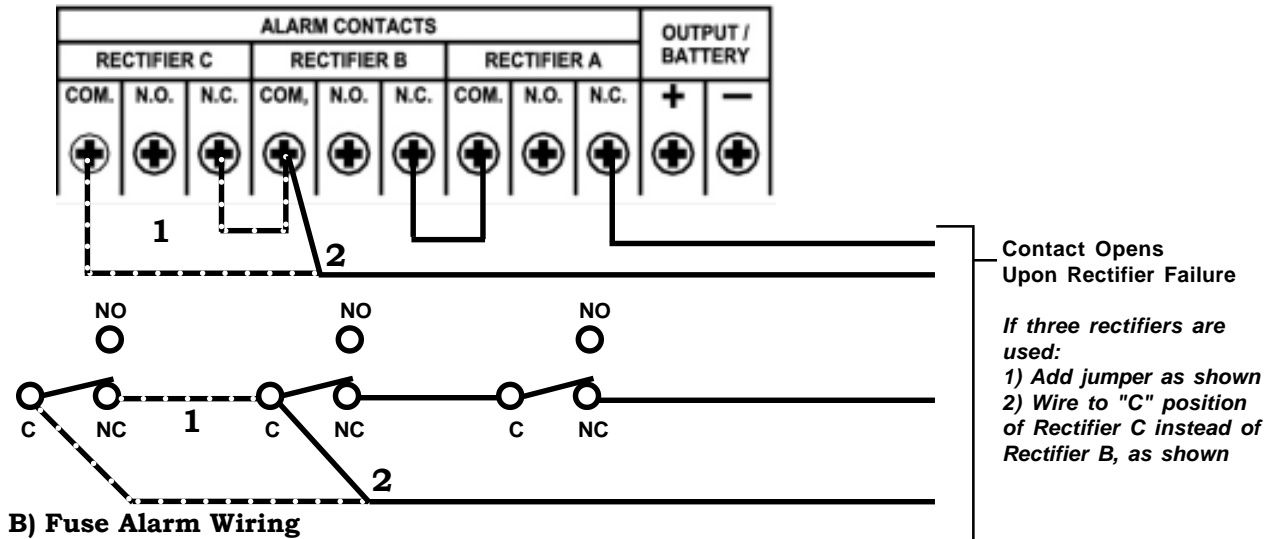

### B) Fuse Alarm Wiring

Form C summary alarm contacts are integral to the optional fuse panel assembly. Blowing of any installed fuse will activate the alarm. The "C", "NO" and "NC" positions are identified with a label directly below the terminal block. For wire installation, refer to the previous section, IV-B.

## VI) BATTERY BACK-UP OPTION/BATTERY MODULE SYSTEM

A battery string can be connected to the Unity Rectifier Shelf (URS) in order to provide battery back-up power in the event of an ac power outage. Following restoration of ac power the Unity system will recharge the battery.

Connect the battery string to the large white nylon terminal strip (center terminal is unused) labeled OUTPUT/BATTERY located on the URS rear. This terminal strip will accommodate 14 to 8 AWG wire size.

**Note:** In order to protect the battery wiring a fuse or circuit breaker should be wired in series with the HOT side of the battery, as close to the battery as possible.

To connect a Battery Module to a URS, first make sure the Battery Module's breaker is in the OFF position. Cut off one of the grey Anderson connectors on the Anderson to Anderson wire assembly supplied with the Battery Module, strip the ends of the 8 AWG wire approx. 3/8" and connect to the large white terminal strip labeled OUTPUT/BATTERY. Be careful to observe correct polarity when connecting the wires to the Unity Rectifier Shelf. Reverse battery connection can cause damage to the Unity Rectifiers. Once connected to the URS, plug the Anderson connector end in to the Battery Module's mating connector and turn its breaker to the ON position.

**Note:** The Battery Module contains a built-in circuit breaker so no external fusing is required.

Contact NEWMAR or visit [www.newmartelecom.com](http://www.newmartelecom.com) for complete specifications on the Battery Shelf/Module System.

## VII) SPECIFICATIONS

### **Unity Rectifiers**

**Input Voltage/Frequency:** 85-264 VAC\* / 47-63 Hz.

**Input Amperage:** 2.2 amps @ 115V and full load, 1.1 amps @ 230V and full load

**Input Frequency:** 47-63 HZ.

**Power Factor:** .96-.98

**Output Voltage/Amperage\*:**

**UR48-3:** -54.4 VDC, adjustable 42-56 VDC / 3 amps continuous

**UR24-6:** +27.2 VDC, adjustable 21-28 VDC / 6 amps continuous

\* 100 % output power available from 105 VAC to 264 VAC;

Derate output linearly from 100% @ 105 VAC to 80 % @ 85 VAC

**Regulation:** +/- 2 %

**Ripple:** UR-24-6: 150 mV; UR-48-3: 250 mV

**Protection:** Over-voltage, current limiting, over-temperature

**Alarms/Indicators:**

Output failure contacts; Form C

Front panel LED indications: "DC OK/DC FAIL", Output Mis-Adjusted, Overload

Front panel voltage test points and adjustment

**Operating Temperature:** -10°C to +60°C; 100 % load to +50°C;

Derate linearly to 80 % load @ 60°C

**Battery Drain (with no AC input):** <10 mA per rectifier

**Dimensions:** Refer to Dimensional Drawings on following page

**Weight:** 1.9 lbs.

**Designed to:**

EN55022 Class B; EN61000-4-2,3,4,5,6,8,11; EN61000-3-2,3; UL 1950

7

**Unity Rectifier Shelf**

**Model URS**

**Input:** 115/230 VAC nominal

**Capacity:** Up to Three Unity Rectifiers, -48 or +24 volt and One GMT Fuse Panel

**Mounting:** 19" or 23" rack

**Dimensions:** Refer to Dimensional Drawings below

**Weight:** 6.7 lbs.

**Unity Fuse Distribution Panel**

**Model UFP-5**

**Voltage:** -48 VDC or +24 VDC nominal (selectable by jumper)

**Current:** 20 amps max. total

**Capacity:** Five GMT fuses, 10 amps max. per individual fuse  
Available Amperages: 1, 3, 5 10 amps

**Alarms/Indicators:**

Output failure summary alarm contacts; Form C

Front panel blown fuse summary LED indicator

Individual visual blown fuse indication

**Dimensions:** Refer to Dimensional Drawings below

**Weight:** .9 lb.

**VIII) DIMENSIONAL DRAWINGS**

