

# Sentinel Power System

## Installation / Operation Manual



## Newmar

2911 W. Garry Ave.  
Santa Ana, CA 92704  
Tel: (714) 751-0488  
Fax: (714) 957-1621

## TABLE OF CONTENTS

<b>Section Description</b>	<b>Page</b>
1.0 Scope .....	3
2.0 System Overview.....	3
3.0 Installation .....	4
3.1 Unpacking & Installing in 19" Rack .....	4
3.2 AC Cabling.....	4
3.2.1 Upstream Over-current Protection.....	4
3.3 DC Cabling.....	5
3.4 Alarm/Ancillary Cabling.....	6
4.0 Alarm Mapping to Volts-Free Relays.....	7
5.0 Circuit Breaker Fail Monitoring .....	8
6.0 LVD Operation.....	8
7.0 DC Earthing Options.....	8
7.1 Dedicated Positive Earth System.....	8
7.2 Isolated System .....	9
8.0 Commissioning.....	9
8.1 System Pre-check.....	9
8.2 Rectifier Start-up .....	9
8.3 Battery Start-up.....	10
8.4 Load Start-up .....	10
8.5 Newmar Essential System Set-up Parameters.....	10
8.6 DC System Commissioning Check-List .....	12
9.0 Maintenance .....	16
Appendix 1 - Rectifier Input Fuse Curves.....	18
Appendix 2 - AC Input Transient Protection .....	19
Appendix 3 - System Wiring Diagrams.....	22

## Receiving Instructions

**CAUTION:**

For your protection, the following information and the product manual should be read and thoroughly understood before unpacking, installing and using the equipment.

We present all equipment to the delivering carrier securely packed and in perfect condition. Upon acceptance of the package from us, the delivering carrier assumes responsibility for its safe arrival to you. Once you receive the equipment, it is your responsibility to document any damage the carrier may have inflicted, and to file your claim promptly and accurately.

### Package Inspection

- Examine the shipping crate or carton for any visible damage: punctures, dents and any other signs of possible internal damage.
- Describe any damage or shortage on the receiving documents and have the carrier sign their full name.

### Equipment Inspection

- Within fifteen days, open crate or carton and inspect the contents for damages. While unpacking, be careful not to discard any equipment, parts or manuals. If any damage is detected, call the delivering carrier to determine the appropriate action. They may require an inspection.  
*Save all the shipping materials for the inspector to see!*
- After the inspection has been made and you have found damage, call us. We will determine if the equipment should be returned to our plant for repair or if some other method would be more expeditious. If it is determined that the equipment should be returned to us, ask the delivering carrier to send the packages back at the delivering carrier's expense.
- If repair is necessary, we will invoice you for the repair so that you may submit the bill to the delivering carrier with your claim forms.
- It is your responsibility to file a claim with the delivering carrier. Failure to properly file a claim for shipping damages may void warranty service for any physical damages later reported for repair.

### Handling

Handle the equipment with care. Do not drop or lean on front panel or connectors. Keep away from moisture.

### Identification Labels

Model numbers are clearly marked on all equipment. Please refer to these numbers in all correspondence with Newmar.

### AC SURGE SUPPRESSION

**WARNING:**

If these systems are used in outdoor cabinet applications, the fitment of a Type 2 AC Surge Suppression Device is mandatory (see Appendix 2).  
**If a Type 2 SPD is NOT fitted, the warranty is void.**

If further advice is required, and/or for supply of an appropriate Type 2 SPD, contact your nearest Newmar representative.

## 1.0 SCOPE

This manual covers essential information for the installation and commissioning of the 1U Sentinel Rectifier System

System set-up for the rectifiers, alarms etc., are provided in separate manuals for the SM35/6 supervisory module and RM648 rectifier.

All installation and maintenance must be carried out by suitably qualified personnel.

**Note 1:** The 1U Sentinel Rectifier System is factory default set with positive earthing (fixed). An option is available for isolating DC output from AC earth – see section 7.2 'Isolated System' for information.

**Note 2:** Please understand the following nomenclature applies:

“Live” = -48 VDC

“Common” = +48 VDC

## 2.0 SYSTEM OVERVIEW

The Sentinel Rectifier System can hold three rectifier modules and have a maximum power output of 1.8kW, producing a maximum current output of 33.3A at 54 VDC. Peak current is 37.5A @ 48 VDC.

The system is intended to be a complete power system in a box, so no connections need to be made internally. AC connection is via rear exiting lead with all the DC (Load and Battery) connections are made at the front of the unit. Alarm connections are accessible from the front.

The system is designed to be extremely simple to install and set up.

The following is a summary of the system:

- Overall size is 483mm wide (19" standard mounting) x 44.5mm/1.75" high (1U) x 280mm/11" deep (within ETSI specification), add 57mm/2.25" to depth for AC cord.
- Up to 3 RM648 series rectifiers - may be packaged separately
- SM36 supervisory module (fully integrated in the system)
- Battery Low Voltage Disconnect fitted as standard (80A rating).
- Up to 2\*x 30A Battery Circuit Breaker, this may be specified as different values at time of order.
- Up to 4x Load Circuit Breaker, this may be specified as different values (6, 10, 15, 20 or 30A) at time of order.
- System weight is approximately 3.6kg/8 lbs. without rectifiers, and 5.6kg/12.3 lbs. with three rectifiers fitted.
- Single phase or split phase lead supplied for input termination (phase, neutral and earth or phase, phase and earth), 110 or 220 VAC.
- Front or rear cable access

\*Installed

### 3.0 INSTALLATION

#### 3.1 Unpacking & Installing in 19" Rack

Upon unpacking, check that the unit is not damaged, and that you have the required number of rectifiers.

Remove the transport bracket supplied attached to the top of the system.

The unit fits into a standard 19" rack. Use the mounting hardware (#12-24 or #10-32) provided with the rack.

Please note the complete system weight is 12.3 lbs. Ensure the 19" mounting rails are able to withstand mounting of the system. The supplied transport bracket can be utilised in cabinets with 19" mounts at the rear of the cabinet to increase the system mounting rigidity if required.

#### 3.2 AC Cabling

The AC cables are clearly labelled at the rear of the system (see Fig 1). The AC cable provided is 14AWG cables and a 115 VAC/20 Amp NEMA 5-20 plug is fitted.

AC connection internally is via .25" QC tabs. Longer cables can be easily fitted by replacing the existing cable. Ensure that the AC colour coding is correct for the country of fitment:

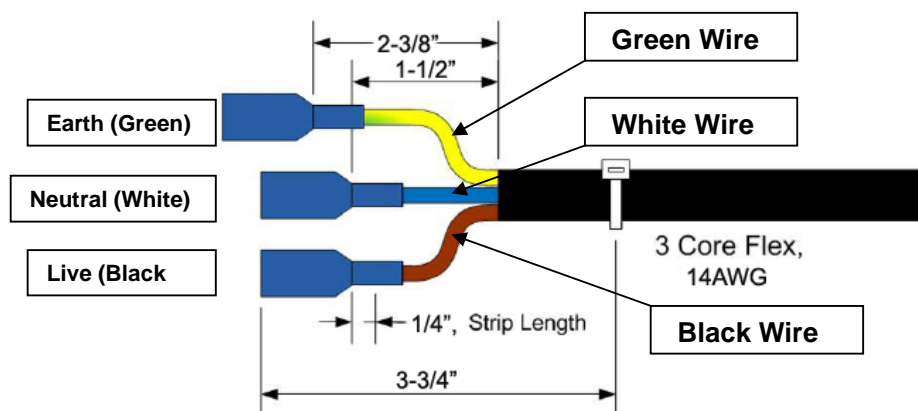

Fig 1, AC Cable Detail

Connections should allow for a maximum single phase AC supply of 16.5A (@ 110VAC) (see next section).

The AC earth is internally bonded to the system chassis.

DC Common (+48VDC) is connected to the AC earth through the placement of the PCB connecting the backplane to the distribution. Alignment depends on required earthing connection. Please see the DC earthing section of this manual (Section 7) for more detail.

**Note:** Please refer Appendix 2 for AC Input Transient Protection.

##### 3.2.1 Upstream Over-current Protection

There are two considerations to take into account when selecting an appropriate fuse/circuit breaker.

- The upstream protection should protect the downstream cable from overload situations.
- Discrimination should be maintained with the downstream device fuses.

### (i) Cable Rating

The maximum current drawn by the DC power system is 16.5A (5.5A per rectifier at a minimum input voltage of 110VAC and full output power). The upstream protection device must be able to supply this load under all conditions without tripping. Therefore, typically at least 20% headroom is allowed for in the protection device, making its minimum rating 20A.

**Note:** The current carrying capacity of cables is dependent on the type of cable used. Please check with your local supplier and local regulations for appropriate sizing.

For convenience, the system is supplied with a 6 feet long, 3-core, 14AWG flex already attached with a NEMA 5-20, 110 VAC, 20 Amp plug. This cable has a current carrying capacity of 20A.

### (ii) Discrimination

Discrimination ensures that the upstream circuit breaker or fuse does not blow if a rectifier input fails (short circuit). Therefore it is important to ensure the upstream protection discriminates with the internal fuse of the rectifier. The fuse used in the RM648 is a slow-blow 10A fuse. The tripping curve for this is shown in Appendix 1 at the rear of this manual.

A minimum circuit breaker to use for this system is a 20A, D-curve (note, a 20A C-curve breaker will **not** discriminate with the rectifier fuse). Therefore, when used with the 14AWG cable supplied, a 20A, D-curve breaker should be used.

Alternatively, a 32A C-curve breaker, or greater, can be used. However, AC cable provided may have to be replaced for a larger cable<sup>1</sup>.

If a fuse is used upstream, then any BS88 or NH g style fuse, of 20A or greater rating will discriminate.

## 3.3 DC Cabling

**CAUTION:** Use extreme care when fitting batteries & their connections. Remove all jewellery and rings from oneself prior to commencing the installation. Always use insulated tools when fitting batteries and take extreme care not to short terminals when working on them.



All DC Load cables terminate to the connectors at the front of the unit as shown in Figure 5. These terminals are all 10AWG maximum wire size. Load connections are of a 'push in' design and cables can be simply pushed into the connector for termination after stripping to the appropriate length.

Removal requires a small screwdriver to be inserted into the rectangular hole above the connector whilst pulling on the cable.



Connector designators are available on the pull-out guide. See Figures 3, 4 and 5 for detail.

<sup>1</sup> NOTE: A larger breaker may be used even though in theory it may appear that the 14AWG wire is not fully protected. In fact it is protected on two accounts. Firstly it is protected by the rectifier input fuse (which is only a short distance away). Secondly, the rectifiers are power-limited on their input. Therefore, they can never be overloaded. As a result, the wire can never be over-loaded by the rectifier – it can only see fault current. As a result, depending on local authorities, only fault current protection may be catered for by the upstream protective device.



Fig 3 & 4, DC Connector detail and pullout guide

The battery cabling connects through the SB50 style power-pole connectors. From here it goes directly to the appropriate circuit breaker, then via a Low Voltage Disconnect relay and current shunt to the internal live bus. This can be seen in the appropriate wiring diagram as the rear of this manual.

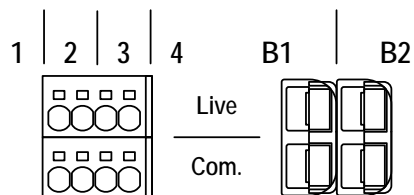

Connector layout for Rectifier Shelf

Fig 5, DC Connector detail

### 3.4 Alarm/Ancillary Cabling

Alarm and communication cables terminate directly into the connectors of the Supervisory Module, SM36, which terminals are assessable by pulling the monitor forward to expose connections (see Fig 6 & 7).

Cables can be routed through the front of the system via the cable exit indicated. When routing the cables, ensure they are kept away from the AC and DC power cables when possible.



Fig 6. For removal, pull monitor forward to release the ball catch



*Fig 7. SM3x cable access*

Relays 1- 6 can be used for normally open or normally closed states by jumper selection. The relay states labelled NO or NC are for their de-energised state. If an alarm is programmed for the relay to be normally energised (as may be required in the case of a low voltage alarm where loss of power will put the alarm into its active state), then be sure to connect the remote wiring appropriately.

For full monitor functionality and operation information, refer to the appropriate monitor manual.

Uncoil the battery temperature sensor and place in the middle of the middle battery string. If the lead is not long enough, ordinary 2-core copper (approx. 18AWG) wire can be used as an extension. The purpose of the battery temperature sensor is to monitor the ambient temperature of the batteries over long periods of time and adjust the rectifier output (float) voltage accordingly. As a result, it is not necessary to have the temperature sensor touching the batteries. If the Battery Temperature Sensor is removed a “battery temp fault” alarm is generated.

For remote communications and direct computer connection to the Sentinel Rectifier System, refer to the monitor manual. These connections can be made via the mini-USB port on the front panel of the monitor (computer connection), and the Ethernet port (SM36 web-based communications only).

#### **4.0 ALARM MAPPING TO VOLTS-FREE RELAYS**

Relay 1 is pre-configured as the “Monitor Fail” alarm. This alarm activates is the monitor has a hardware fault or if software becomes corrupted.

All other relays can be mapped to different alarm conditions. The monitor manual details how these may be changed. On the standard Compact Systems alarms are preconfigured as follows:

Relay 2: Summary Non-urgent alarm

Relay 3: Summary Urgent alarm

Relay 4: User Configurable

Relay 5: User Configurable

Newmar ■ PO Box 1306, Newport Beach, CA 92663

■ Phone: 714-751-0488 ■ E-mail: [techservice@newmarpower.com](mailto:techservice@newmarpower.com)

## Relay 6: User Configurable

As mentioned, if these mappings are not appropriate, they can be changed in the field to suit customer requirements.

### 5.0 CIRCUIT BREAKER FAIL MONITORING

The load circuit breakers are monitored electronically through an internal general purpose input on the monitor. The digital input will trigger an alarm when it is pulled to the system common (+ve or -ve depending on configuration) rail. This means that to operate the load must be connected. In this way, false alarms are avoided when no load is connected and all load circuit breakers are in the “off” position.

**Note:** This also means that a residual voltage will be measured at the load terminal even when the circuit breaker is turned off. This is high impedance and does not present a hazard to the user.

The battery circuit breakers however, use voltage sense to detect tripping or whether they are turned off. This is because when a battery breaker is tripped, there may be very little voltage difference across the breaker, making electronic fail detection problematic. Hence, if no battery is connected, the breaker must be “on” to clear the Battery Breaker Fail alarm.

### 6.0 LVD OPERATION

This system is configured with a single Low Voltage Disconnect contactor in the battery side of the circuit (see wiring diagram at rear of this manual).

The supervisory monitor unit is powered from both the rectifier side of the LVD contactor and battery source. Therefore when the low voltage threshold is reached and the LVD disconnects the battery, the SM3x will lose voltage sense (as voltage sense is measuring rectifier bus voltage) but still maintains operation for monitoring system. The LVD contactor will not re-engage until the rectifier power is restored (i.e., until the DC bus voltage is restored).

### 7.0 DC EARTHING OPTIONS

#### 7.1 Dedicated Positive Earth System

The 1U Sentinel system is a positive earth system where the positive DC output is tied to AC earth as shown in figure 8.

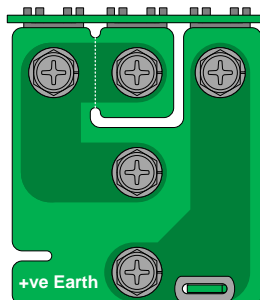

Fig 8, +ve earth option

## 7.2 Isolated System

For systems that require no connection to earth, the PCB can be cut as indicated in figure 9 to isolate DC output from AC earth.

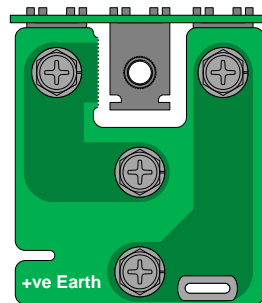

Fig 9, isolated earth option

## 8.0 COMMISSIONING

Use the following set of instructions as a guide, unless different procedures are recommended by local authorities.

**Note:** Refer to Section 8.5 to check important system setup parameters while commissioning. This should be checked for all systems installed. Section 0 is provided as a template in case detailed commissioning is required.

### 8.1 System Pre-check

1. System installation is completed.
2. Battery and load circuit breakers are turned off, and upstream AC has been turned off (i.e., system is completely de-powered).
3. Rectifier modules have been placed into their shelf positions, and pulled forward enough to disconnect them from the system.
4. Check that the protective AC Earth is connected as per local regulations.

**Note:** This system is available in either positive earthing (-48VDC) or negative earthing (+48VDC) configurations. Before connecting batteries or rectifiers ensure that the correct system has been specified and earthing is correct for your application.

5. Turn on AC upstream and check that voltage from phase to neutral are as expected.

### 8.2 Rectifier Start-up

1. Turn the upstream AC circuits on.
2. Fully insert first rectifier, wait for the rectifier to start and its power on LED to remain green.
3. Check the SM3x powers up, and indicates the system default float voltage on its display. If the audible alarm activates, press any button to silence it.
4. If a different system float voltage has been specified, set this at this time using the procedure specified in the SM36 Manual (either from the front panel or connected computer).
5. Fully insert the rest of the rectifiers ensuring they power up with only their green "power on" LED illuminated.
6. Check that the load and battery currents on the SM36 are 0 amps (+/- 1 or 2 amps).
7. Check that all SM3x configuration settings are correct (as per customer specification) with respect to:

Newmar ■ PO Box 1306, Newport Beach, CA 92663

■ Phone: 714-751-0488 ■ E-mail: [techservice@newmarpower.com](mailto:techservice@newmarpower.com)

- Voltage levels
- Alarm settings
- Alarm mappings to the volts-free relays  
(refer to the SM3x manual for information on how to check these via the front panel or locally connected computer).

### 8.3 Battery Start-up

**Note:** It is important that battery circuit breaker connections should be made when the rectifiers are turned on and the system is “live”. This is because the system voltage and battery voltages will be similar, thus minimising any arcing during connection. This also prevents high current arcing due to the charging of the rectifier output capacitors.

1. Fit only one rectifier initially (to limit any damage if any connections are incorrect).
2. Measure the voltage across each battery string at the terminals of the Sentinel System. Ensure that the reading from the DC Common bus to the Battery Live Terminals is -48V. Verify the Anderson connector wired to 48 volt battery string are wired correctly: positive (+) connector to +48V battery post and negative (-) connector to -48V battery post.
3. Turn on each battery circuit breaker in succession while measuring the battery voltage and ensure that the voltage increases slightly to the system Float Voltage (typically the voltage will increase from 2-3V below float to float voltage). At this point the batteries will be drawing some current to bring them to a full state of charge.

### 8.4 Load Start-up

1. Ensure downstream load connections have been made and there are no loose/floating cables.
2. Turn on load circuit breaker, ensuring that the downstream equipment is being powered up as expected.
3. Ensure the system float voltage on the SM36 is at the level previously noted.
4. Ensure the load current is at a level expected (could be zero if loads downstream have not been connected).

**Note:** Prior to leaving the system after it has been commissioned, ensure all AC, DC *and* battery circuits are off. If it is required that the system is to be left on (to power load equipment), ensure rectifiers are left in their powered up state, and batteries are in circuit. This will prevent anyone leaving the batteries only powering the load (in which case the batteries would go flat).

### 8.5 Newmar Essential System Set-up Parameters

The following items 1 through 5 are system settings that **MUST** be checked for **EACH** system installed, at the time of commissioning.

**WARNING:** Failure to correctly follow the procedures in items 1 to 5 below may at least cause incorrect system function, and at worst **ruin** your battery (**without** the ability to claim battery replacement under warranty).

**PRIOR** to making any changes to settings, ensure that you back up the Configuration settings that the SM36 is supplied with. To do this, go to the Setup page and click on the “Save Variable to File” button. The filename is saved with a “.sm36” extension.

#### 1. Check/Set Float Voltage

Consult battery manufacturer’s data for proper setting.

The Float voltage is for 25°C reference temperature in Newmar systems.  
SM36 Config Page: [Power Module Control](#)

Rectifier Float Voltage Setpoint	<input type="text" value="54.00"/>	V
----------------------------------	------------------------------------	---

Done: 

## 2. Set Battery Settings

Temperature Compensation

You **must** consult the battery manufacturer's data to obtain the correct Slope setting.

SM36 Config Page: [Charge](#)

Temperature Compensation		
<input checked="" type="checkbox"/> Enabled		
Temperature Slope Compensation	<input type="text" value="-3.0"/>	mV/°C/Cell
Temperature Min Control limit	<input type="text" value="0.0"/>	°C
Temperature Max Control Limit	<input type="text" value="50.0"/>	°C
Number of Cells	<input type="text" value="24"/>	

Done: 

If you choose **not** to enable Temperature Compensation, then set the Rectifier Float Voltage to that required by the battery manufacturer for the average long-term temperature you anticipate your system to operate at.

## 3. Battery Size

For the SM36 to set the correct Battery Current Limit current, it is essential that this is filled out correctly. These figures are also used for estimating the Battery Time Remaining during a discharge.

For Telecom applications, the 10 hour rate is usually the name-plate rating of the battery.

However, once again, check the battery manufacturer's data sheets as some manufacturers state the 20 hour rate (which is usually a little more "optimistic").

The second rate is required specifically for the time-remaining algorithm. A 4 hour rate is usually a good one to use. This information is available from the battery manufacturer's data sheet.

SM36 Config Page: [Charge](#)

Battery Capacity				
Capacity At	<input type="text" value="10"/>	Hour Rate	<input type="text" value="100"/>	Ahr
Capacity At	<input type="text" value="4"/>	Hour Rate	<input type="text" value="73.6"/>	Ahr
Discharge Time Remaining	<input type="text" value="---"/>			Minutes
10 Hour Rate Capacity Remaining	<input type="text" value="100"/>			%

Done: 

**Note** – you need to change both the 10 hour and 4 hour rates at the same time. The rates need to be reasonably accurate (in terms of the proportion of 4 hour to 10 hour rates), otherwise the SM36 may not accept the settings.

## 4. Battery Current Limit

The Battery Current Limit is set as a percentage of the 10 hour rate entered in step 3.

SM3x Config Page: [Control](#)

Battery Charge Current Limit	
<input checked="" type="checkbox"/> Enabled	
Battery Charge Current Limit	<input type="text" value="25"/> %

Done: 

Newmar recommends that you set this value at the highest rate possible to ensure the battery is recharged as fast as possible (this could be as high as 30%, depending on the manufacturer).

Newmar ■ PO Box 1306, Newport Beach, CA 92663

■ Phone: 714-751-0488 ■ E-mail: [techservice@newmarpower.com](mailto:techservice@newmarpower.com)

However, especially in large systems, this may be more limited by the number of rectifiers available, rather than this particular setting. For telco settings, this is often set to 10% (or  $0.1C_{10}$ , so for a 100Ahr battery, the current limit is 10A). This is more typical of a design parameter than the need for the setting to be at this level. So a setting higher than this level should be considered to enable the fastest recharge possible. However, consult the battery manufacturer data to find the maximum value.

### 5. Low Voltage Disconnect Settings

SM36 Config Page: Alarms (Levels)

Low Voltage Disconnect Setpoint		
LVD1 Disconnect Setpoint	<input type="text" value="43.00"/>	V
LVD1 Reconnect Setpoint	<input type="text" value="48.00"/>	V
LVD2 Disconnect Setpoint	<input type="text" value="10.00"/>	V
LVD2 Reconnect Setpoint	<input type="text" value="15.00"/>	V
LVD3 Disconnect Setpoint	<input type="text" value="10.00"/>	V
LVD3 Reconnect Setpoint	<input type="text" value="15.00"/>	V

Done:

This is usually a customer generated setting. Normally, the longer the discharge, the higher the end voltage. So, for a discharge of <1hr, this may be 1.75Vpc (42.0V for a “48V” battery), or for an 8 hour discharge, it may be 1.85Vpc (44.4V for a “48V” battery).

Note that if only one LVD is fitted, then the other thresholds (of LVD2 & LVD3) are normally set well outside of possible tripping voltages. Although not essential, and those LVDs will not be enabled anyway, it serves to avoid any confusion over which LVD signal is actually being used.

### 8.6 DC System Commissioning Check-List

DC SYSTEM COMMISSIONING CHECK-LIST				
Site Name: _____			Date: _____	
Tests Without Batteries Connected		Measured/ Setting	Results	
	Check Float Voltage	Meter: _____	_____ V	✓ / ✗
	Check Load Current	Meter: _____	_____ A	✓ / ✗
<b>Alarms:</b>				
Voltage thresholds can either be checked using an external power supply, or by adjusting the SM36 float voltage 0.1V above (or below for the low voltage alarms). It is recommended to have the batteries <b>disconnected</b> .				
<ol style="list-style-type: none"> <li>Adjust the supply/float voltage to 55.7V &amp; observe the “High Float” alarm.</li> <li>Adjust the supply/float voltage to 57.7V &amp; observe the “High Load” alarm.</li> <li>Adjust the supply/float voltage to 52.7V &amp; observe the “Low Float” alarm.</li> </ol>				

4. Adjust the supply/float voltage to 46.9V & observe the "Low Load" alarm.			
High Load Volts (urgent)	57.6V	_____ V	✓ / ✗
High Float Volts (non-urgent)	55.6V	_____ V	✓ / ✗
Low Float Volts (non-urgent)	52.8V	_____ V	✓ / ✗
Low Load Volts (urgent)	47.0V	_____ V	✓ / ✗
<p>Depending on the test load available, it may be necessary to adjust the High Load Current alarm threshold down to suit. For example, with 40A test load, adjust the High Load Current threshold (use SM36 Config. software, click on the "Alarms/(Levels)") to 35A. Then simply apply the 40A load and observe the alarm change state.</p> <p>Once the test is complete, be sure to rest the High Load Current to its previous value (or check with the customer for the correct value they require).</p>			
High Load Current (urgent)		_____ A	✓ / ✗
<p>Temperature alarm tests are performed by heating up (using a heat gun or other source) and cooling down (using a aerosol can of freeze, or a tub of ice) the temperature sensors.</p>			
Battery Temperature High (urgent)		_____ °C	✓ / ✗
Battery Temperature Low (non-urgent)		_____ °C	✓ / ✗
Room Temperature High (non-urgent)		_____ °C	✓ / ✗
Room Temperature Low (non-urgent)		_____ °C	✓ / ✗
<p>When an AC Monitoring PCB is not fitted at system level (as in most cases), the AC Fail alarm is generated from the rectifiers. The rectifiers sense if AC is present, and extend an AC fail alarm to the SM36. Therefore, to test this alarm, simply turn off the rectifier AC breakers. To allow the monitor to continue to read alarms there must be DC present on the output of the system.</p> <p>As this causes the rectifier output to cease, a Rectifier Fail alarm is also generated. To generate the Urgent Rectifier Fail, turn off the required number to make this occur (usually set to 2, but check via the SM36 Config software for the setting (under the "Rectifier Control" section of the "Control" tab)).</p>			
AC Fail (urgent)		Urgent	✓ / ✗
Rectifier Fail (non-urgent)		Non-urgent	✓ / ✗
Urgent Rectifier Fail (urgent)		No. Modules: _____	✓ / ✗
<p>To check Load MCB fail, connect a load, but with no load turned on. Then switch the breaker to it's off position, and turn on some load (any amount will do). This will cause the alarm to occur as the load side to the circuit will be taken to system common voltage. Turn off the load, and then return the breaker to its on position.</p>			

	Load MCB Fail (urgent)			✓ / ✗
	<p>A Rectifier Off Normal alarm is generated with the rectifier enters a state that may degrade its performance (e.g., a single fan fail), or a state that is outside of normal operating conditions (e.g., high temperature, or current limit).</p> <p>You can observe an Off Normal alarm when the system is placed in current limit, or you may wish to stop a fan to generate the alarm. The best way to stop a fan is to use a small cable tie (non-metallic), and push it approximately 1cm through the rectifier grille.</p>			
	Rectifier Off Normal (e.g., fan failed) (non-urgent)			✓ / ✗
<b>Tests with Batteries</b>				
	<ul style="list-style-type: none"> <li>• Turn off Battery Breaker/s</li> <li>• Connect battery/batteries</li> <li>• Check the correct Battery Capacity (Ahrs) has been entered (SM3x Config., "Charge" tab, top right of screen). This is the total capacity, so for example 100Ahr strings in parallel, this should be 200.</li> <li>• Go to SM36 Config., "Control" tab. Set the Battery Charge Current Limit to "Enabled" (middle right of screen). Also check Battery Current Limit (BCL) is set to desired level (usually <math>0.25C_{10}</math>, (25%)). This means that for a single 100Ahr battery, the BCL will be 25A, or if two 100Ahr batteries are connected in parallel, the BCL will be 50A.</li> <li>• Go to SM36 Config., "Battery Monitoring" tab. "Tick" Logging Enabled. Set: <ul style="list-style-type: none"> <li>- Status Log Sampling Interval to 7 days (provides a "snapshot" of the battery state every 7 days)</li> <li>- Discharge Log Sampling Interval to 1 minute</li> <li>- Discharge Log Continuation Time to 5 minutes (this is the length of time logging continues for after AC power is returned)</li> </ul> </li> <li>• Connect load (but turn off).</li> <li>• Check <math>V_f</math> is set to 54.0V.</li> <li>• Turn on Battery Breaker/s</li> </ul>			
	Check Battery current is positive if charging			✓ / ✗
	<p>For systems fitted with Battery Monitoring (BCM) cards:</p> <p>Go to SM36 Config., "Battery Monitoring" tab and "tick" start scanning. Check that the all the battery cell voltages are approximately the same, at about 2.25V (or 13.5V for 12V monoblocs). If any are out by a large amount, then check the BCM sense wiring is correct.</p>			✓ / ✗

	Set load to required level (e.g., 30A), Initiate Battery Discharge Test (from SM3x Config., "Charge" tab, click "Battery Test Enabled")		Check operates	✓ / ✗
	Check Battery Current is negative (discharging)			✓ / ✗
	Check Battery Current	Meter: _____	_____ A	✓ / ✗
	After several minutes, or until the battery voltage has dropped below approx. 47V, "un-tick" (stop) Battery Test (from SM3x Config., "Charge" tab). During this time the Battery Condition Monitor (if fitted) will be logging every minute.			
	Battery Current Limit (BCL)  Check that the battery recharge current is limited to the Battery Current Limit level (usually 0.25C <sub>10</sub> , (25%))  Note: as the BCL is based on fine voltage control of the system bus, the BCL make take one or two minutes to "settle", i.e., you may observe a brief excursion of the battery recharge current beyond the BCL setting.		BCL functions  _____ %	Yes/No
	Check Manual Equalise (if configured)			✓ / ✗
	A Battery MCB Fail alarm is generated from the voltage measured across the battery MCB.  Therefore, to check a Battery MCB Fail alarm, simply open one of the battery MCB's. If batteries are connected to the system at this time, the alarm may take a few moments to activate. Once test is complete, turn breaker back on.			
	Battery MCB Fail (urgent)			✓ / ✗
<b>Temperature Compensation</b>				
	Ensure Temperature Compensation Enabled			Yes/No
	Apply heat or cold to the Battery Temperature Sensor/s. Check the float voltage moves up or down as expected.			Yes/No
	If actual measurement is required, apply a known heat or cold to the sensor. Allow it to fully come to temperature, and record the amount of voltage movement.		Temp. _____ °C  Voltage offset: _____ V OK?	Yes/No
<b>Check Alarm Relay Contacts</b>				
	To generate these alarms, refer to the procedures described earlier in the Commissioning Check-list.			

	Spare relays will not be able to be tested unless an alarm is mapped to them. As these are tested in the factory, it is not essential to test them at time of commissioning.			
On main SM3x PCB				
	Relay 1 (Monitor Fail) (pull out the RJ45 lead connecting the monitor to the system rectifier shelf – this simply de-powers the monitor)			✓ / ✗
	Relay 2 (Summary Non-urgent)			✓ / ✗
	Relay 3 (Summary Urgent)			✓ / ✗
	Relay 4 (Spare)			✓ / ✗
	Relay 5 (Spare)			✓ / ✗
	Relay 6 (Spare)			✓ / ✗

**Note:** *Prior to leaving the system after it has been commissioned, ensure all AC, DC and battery circuits are off. If it is required that the system is to be left on (to power load equipment, ensure rectifiers are left in their powered up state, and batteries are in circuit. This will prevent anyone leaving the batteries only powering the load (in which case the batteries would go flat).*

## 9.0 MAINTENANCE

As NEWMAR Power Systems are state of the art electronic systems, very little routine maintenance is required

### System

- Check all load and battery & alarm cable connections are tight.

### Monitor

- The monitor can give a good indication of the condition of the system. Alarm logs can show issues with the system and rectifiers and should be regularly checked.
- As a minimum, check that the float voltage and load current is as expected.
- If the batteries are fully charged, check the battery current is zero or near to zero amps, and also check that the amp-hours remaining (found in the SM32 Configuration Software application, under the heading “Charge – Battery Capacity”) is 100%.

### Rectifiers

- During normal operation some dust will build-up on the front of the rectifiers. This should be kept to a minimum by regularly wiping the rectifiers to avoid accumulation within the rectifiers and blocking the airflow to the units. The positioning of the system and surroundings will determine the regularity of this requirement.
- In extremely dusty positions it is recommended that the units are removed and cleaned with compressed air to prevent airflow blockages.

## Batteries

- Battery maintenance will depend on the individual manufacturer's specification, please contact the battery supplier for recommendations.

APPENDIX 1 - RECTIFIER INPUT FUSE CURVES

\* The curves are average value, for reference only \*

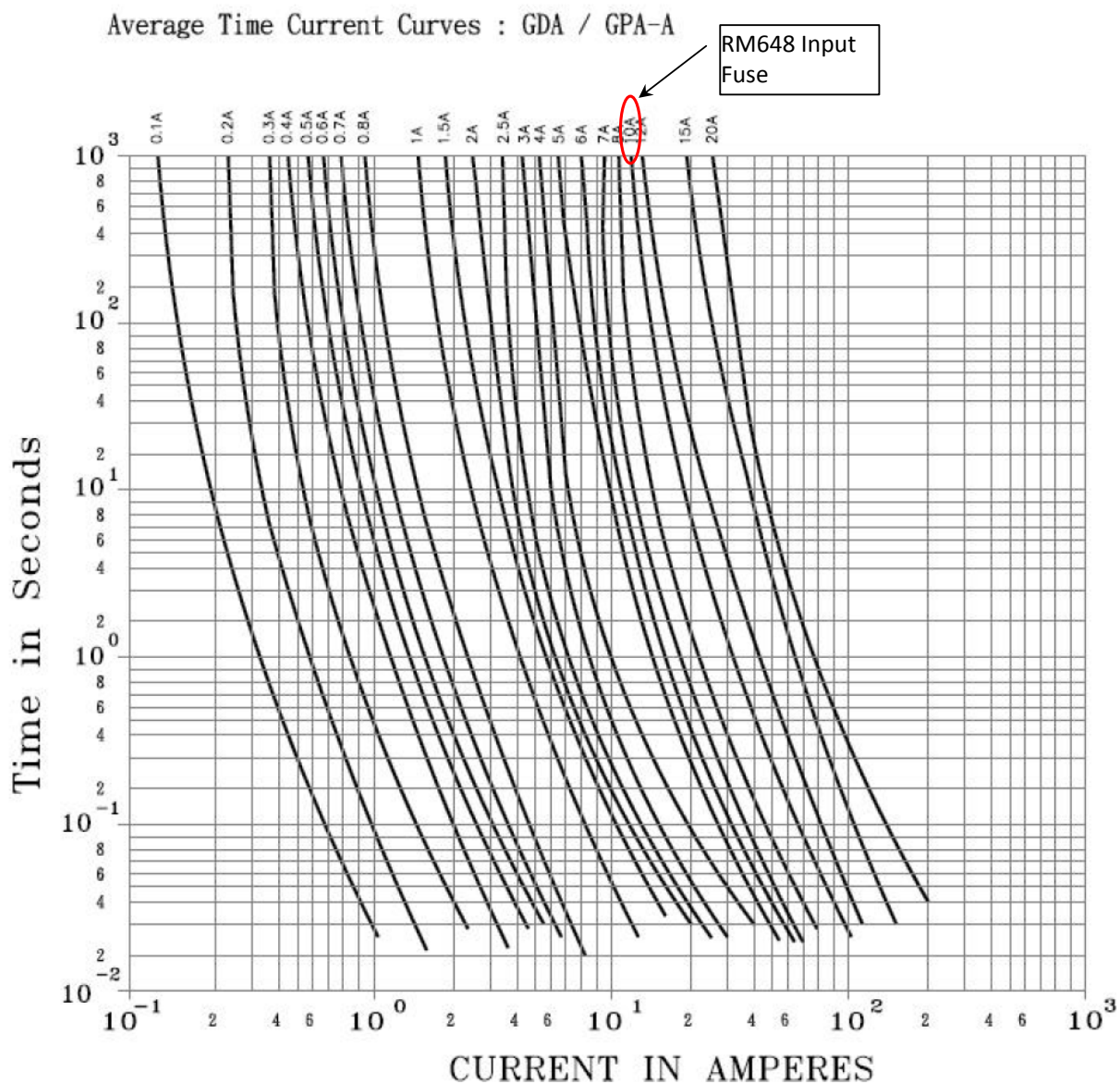

## APPENDIX 2 - AC INPUT TRANSIENT PROTECTION

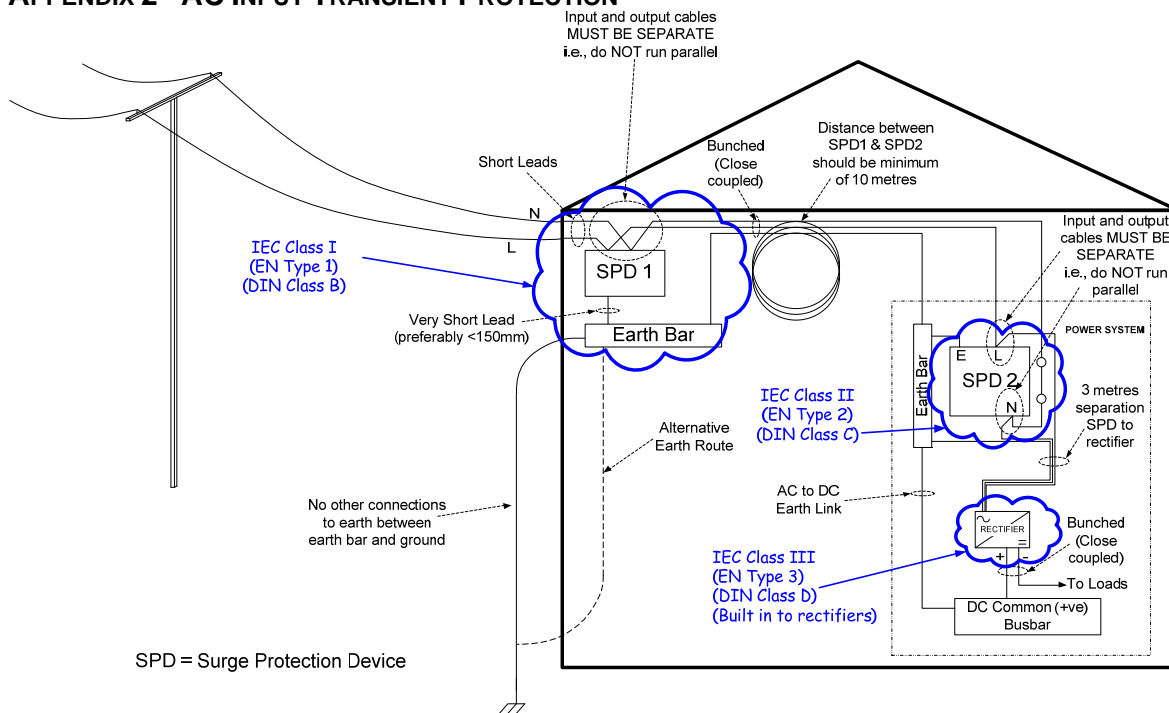
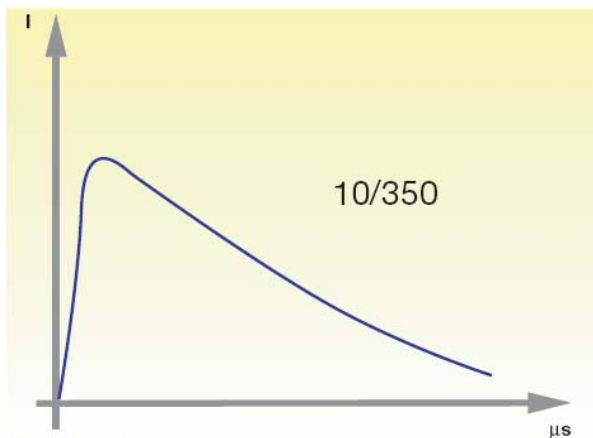

**Figure A**

Fig. A illustrates the surge protection installation principles, utilising the 3 stage protection zone concept.

The **Type 1** (SPD1) surge arrester, fitted in the installation's main incoming electrical switchboard, is capable of diverting the energy of a direct lightning strike. This is the first stage of the electrical network's protection. It is important that upstream Type 1 protection is provided on site. Although the actual surge capability of the device used can vary depending on the severity of lightning in any particular installation, the typical maximum discharge current of a Type 1 surge suppressor will be in the order of 50kA to 100kA (10/350µs impulse)

The 10/350µs current wave as shown below is the standardized current waveform which passes through equipment when subjected to an overvoltage due to a direct lightning strike.



Type 1 Surge Arresters  
I<sub>imp</sub>: current wave

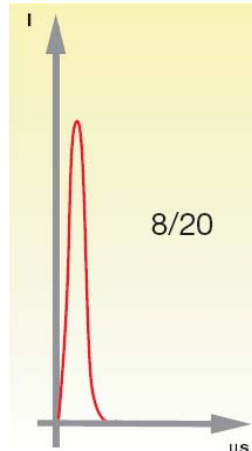

Type 2 Surge Arresters  
I<sub>max</sub>: current wave

A **Type 2** surge arrester (SPD2) should be used in coordination with the incoming **Type 1** surge arrester. This is the second stage of protection. The Type 2 Surge arrester is designed to run-off energy caused by an overvoltage comparable to that of an indirect lightning strike or an operating overvoltage (this is effectively the “left-over” surge from the Type 1 protection device). To provide sufficient de-coupling between the Type 1 and Type 2 devices, impedance is required. This is typically stated to be 10m of cable (approximately 10 $\mu$ H). This cable may be looped if the distance available is too short. Alternatively various manufacturers have devices which act as filter elements or provide active spark ignition for applications where 10m of cable is not practical (such as outdoor enclosures).

**Note:** Newmar Rectifiers are compliant with EN61000-4-5, Level 4 without any external/upstream surge suppression. To maintain a coordinated approach to surge suppression, Type 2 SPD should be installed upstream if not fitted in the system.

**WARNING:** If these systems are used in outdoor cabinet applications, the fitment of a Type 2 AC Surge Suppression Device is mandatory.  
**If a Type 2 SPD is NOT fitted, the warranty is void.**



If further advice is required and/or for supply of an appropriate Type 2 SPD, contact your nearest Newmar representative.

#### Notes on AC cable installation and SPDs

The following precautions must be adhered to when installing AC cabling.

1. Avoid running input and output cables from AC Surge Protection Devices together:

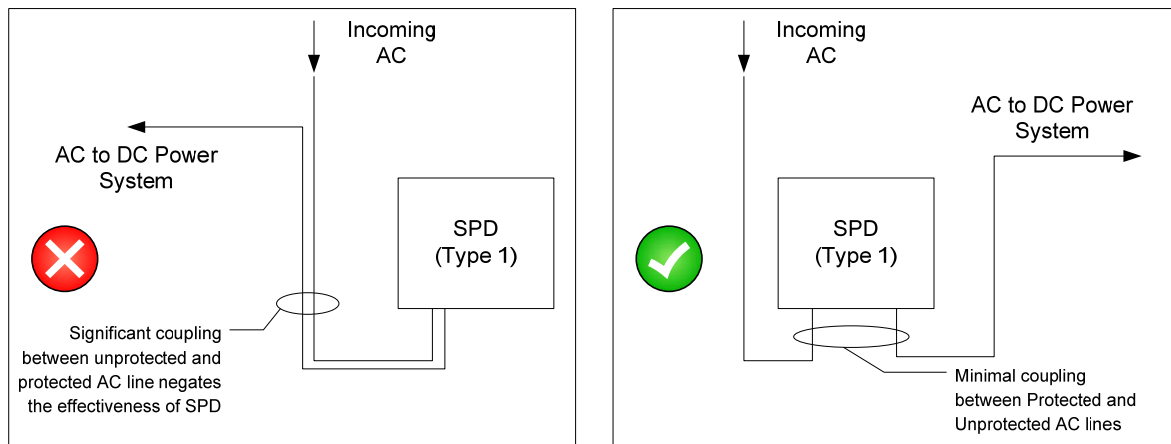

## 2. Avoid "Tee'd" Connections:

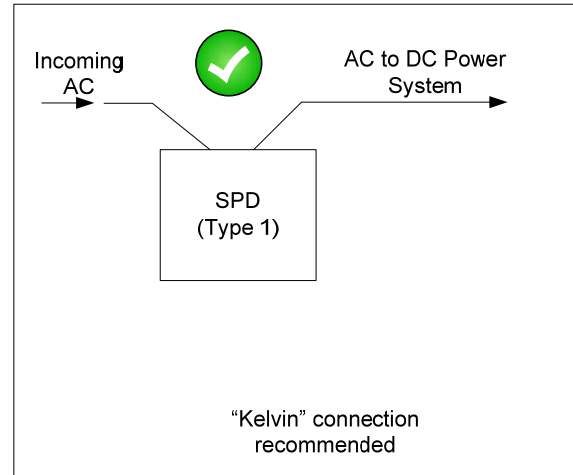
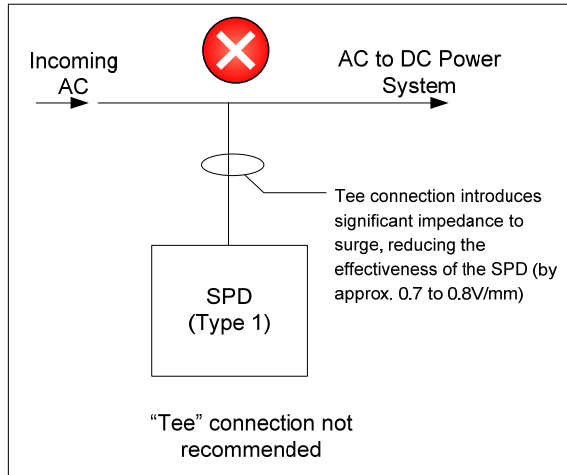

### APPENDIX 3 - SYSTEM WIRING DIAGRAMS

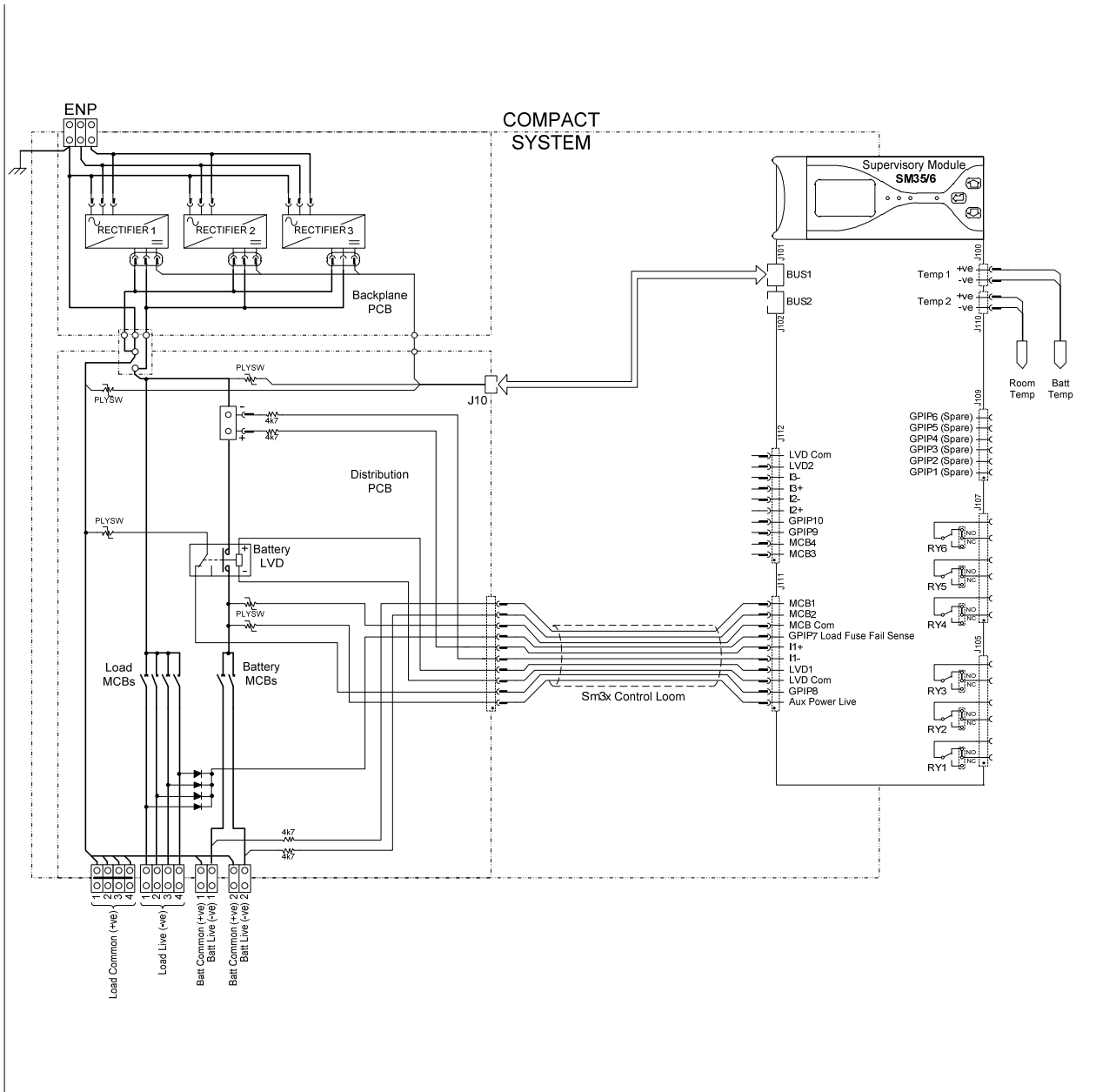

<b>System Ratings:</b>	
Nominal Output Voltage:	-48VDC
Max. Output Current (RM648):	37.5A @ -48V 33.3A @ -54V
AC Input (total):	9.3A @ 220V <sub>in</sub> 18.5A @ 110V <sub>in</sub>