

Power Function Manager

MODEL: PFM-400



(Unit shown with optional breakers installed)

INSTALLATION / OPERATION MANUAL

CONTENTS

<u>SECTION</u>	<u>TOPIC</u>	<u>PAGE</u>
I)	OVERVIEW	3
II)	INSTALLATION	3
	A) Materials Provided.....	3
	B) PFM Mounting.....	3
	C) Bus Bar Mounting.....	3
	D) Input Wiring.....	4
	Quick Connect Wiring Option	
	Standard Wiring	
	E) Output Wiring.....	6
	Unswitched Output	
	Switched Output	
	F) Battery Wiring.....	9
	G) Status and Alarm Contact Wiring.....	9
	H) Chassis Grounding.....	12
	I) Circuit Breakers.....	12
	Breaker Installation	
	Breaker Functions	
III)	STATUS INDICATORS	14
	A) Output Voltage/Current Meter.....	14
	B) "BATTERY ON LINE" L.E.D.....	14
	C) "CHECK SYSTEM" L.E.D.....	15
	D) LVBD "OPEN" L.E.D.....	15
IV)	LOW VOLTAGE BATTERY DISCONNECT	15
	A) Circuit Purpose.....	15
	B) Adjusting the Connect/Disconnect Voltages.....	16
V)	TROUBLESHOOTING	17
VI)	SPECIFICATIONS	19
VII)	BREAKER SPECIFICATIONS/ORDERING GUIDE	19

M-PFM400
As of June 2001

QUICK REFERENCE CONTENTS

Each of the main front or rear panel accessible features of the PFM-400 is illustrated below, along with the page number where information on that particular feature is located.

FIGURE 1: PFM FRONT PANEL

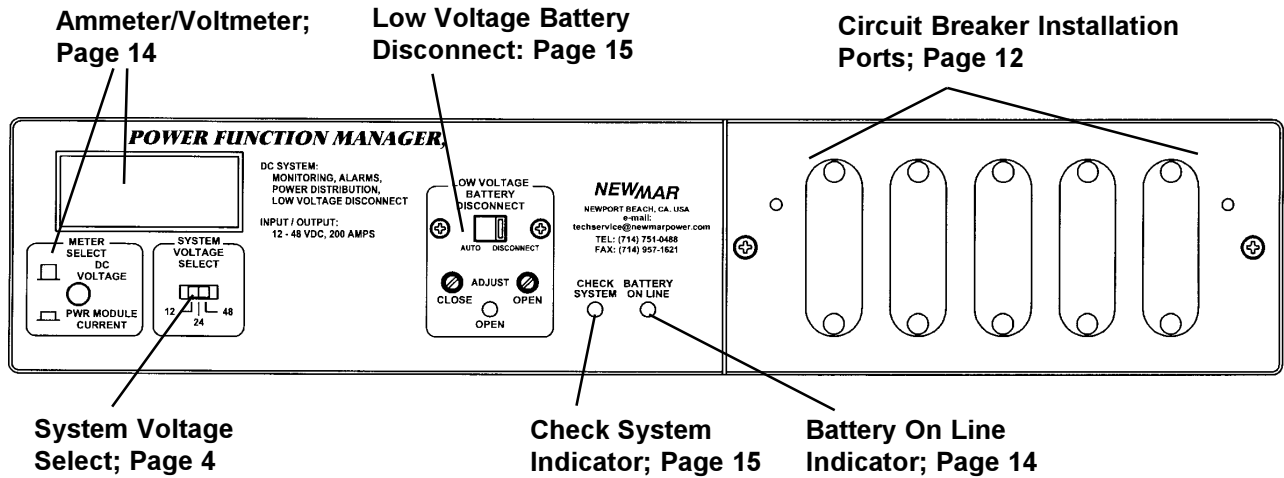
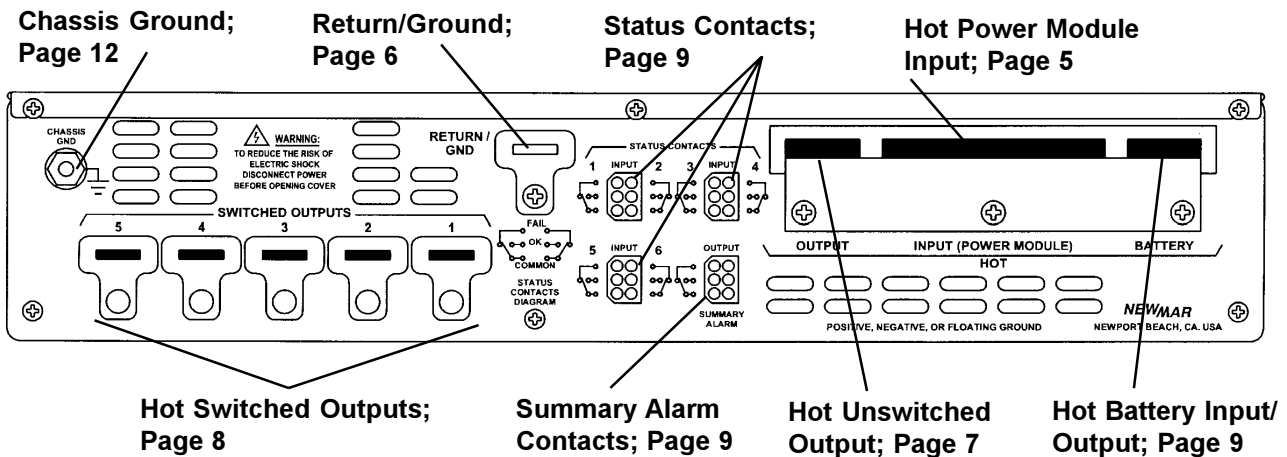

FIGURE 2: PFM REAR PANEL



I) OVERVIEW

The Power Function Manager (model PFM -400) converts multiple d.c. power sources (or NEWMAR Power Modules) into a fully integrated and multi-functional power system. The unit provides control, monitoring, paralleling and protection of 12V, 24V or 48V d.c., positive, negative or floating ground power sources.

A heavy duty (400 amp) parallel bus bar, digital metering, individual power source and total system status lights, five load distribution breaker capacity, low voltage battery disconnect and summary alarm contacts are all combined into the compact, rackmount housing of the PFM, which serves as a master d.c. power management and distribution center.

The PFM may be used for integration, control, monitoring and protection of numerous different types of power sources, such as AC-DC rectifiers, regulated power supplies or DC-DC converters. In addition, any rack power product, including distribution panels, can be connected to the PFM's alarm system, provided they employ form C or Normally Open (NO) alarm contacts. For simplicity of explanation in this manual, reference is made to the NEWMAR Power Module as the power source(s).

Note: Installation of Oring diodes is required for paralleling of d.c. power sources. Oring diode output is standard on NEWMAR PM Series Power Modules.

II) INSTALLATION

A) Materials Provided

Prior to installation, please check to see that each of the following items have been included with the PFM. Check both the information packet and the cardboard insert which is labeled "ACCESSORIES INSIDE". For any missing items please contact the factory or warehouse.

- (2) ea. Mounting Ears for 19" rack mounting
- (2) ea. Mounting Ears for 23" rack mounting
- (6) ea. 6-32 X 1/4" Phillips Screws (for mounting ear installation)
- (1) ea. Circuit Breaker Cover
- (1) set Circuit Breaker Identification Labels
- (1) ea. Status Contact Wiring Harness
- (1) ea. Molex "Pigtail" Connector (six-wire)
- (1) ea. BBA-400 Bus Bar Assembly Kit (see BBA instruction sheet for parts diagram)
- (1) ea. Installation/Operation Manual
- (1) ea. Customer Satisfaction/Warranty Card

B) PFM Mounting

The PFM is designed for mounting in a 19" or 23" relay rack and occupies two rack-units (2RU; 3.5"). Two sets of mounting ears and six 6-32 x 1/4" pan head phillips screws for attaching the ears to the PFM chassis are provided. Select the appropriate mounting ear set and fasten to the PFM. Attachment holes in the chassis are provided

to allow either flush or center mounting.

C) Bus Bar Mounting

The PFM is shipped with a rack-mount ground bus bar assembly kit (BBA-400). The bus bar is typically mounted on the rear of the rack and is designed for installation on 19" or 23" racks using the provided mounting brackets and isolated stand-offs. Refer to the instruction sheet provided with the BBA for complete mounting instructions and specifications.

BBA and PFM Rack Location Note: When wiring multiple power sources for parallel n+1 redundant wiring, equal length positive and negative conductors are required for optimum load current sharing. Mounting the BBA at the opposite end of the rack as the PFM (i.e., PFM at top-of-rack; BBA at bottom, or vice versa) will help facilitate equal length conductor wiring.

D) Input Wiring

Important Pre-Wiring Note: Prior to any wiring of the PFM, the appropriate input voltage must be selected. Using a ball-point pen or similar object, slide the recessed SYSTEM VOLTAGE SELECT switch on the front panel into the appropriate 12, 24 or 48 volt position. The unit will operate with positive or negative ground.

Simplified Wiring Option: d.c. Quick Connect Wiring Kit

A d.c. wiring harness quick connect kit is available from NEWMAR which simplifies parallel wiring installation of multiple Power Modules with the Power Function Manager, and also facilitates "hot change-out" of modules for repair or replacement. *Note: This option is available only for systems which incorporate 1,000 watt models of the NEWMAR PM Series Power Modules.*

The kit consists of a power wiring harness with wires which are pre-cut to proper length and properly terminated with ring lugs. The harness is neatly tie-wrapped into proper position for a simple and professional installation.

Two kits are available: QCK-3 for wiring up to three Power Modules, and QCK-6 for wiring four to six modules. For more information or to order the quick connect kit, please contact the factory.

Note: If using the QCK for Power Module/PFM wiring all Power Modules must be stacked in the rack, one atop another, above the PFM. (See FIGURES 3, 4 or 5)

Standard Wiring Instructions

Up to six power modules with the same voltage output may be wired to the PFM input, with the total load current not to exceed 400 amps.

Refer to FIGURE 3 on the following page for the PFM input wiring instructions which follow.

FIGURE 3: Typical PFM d.c. Input Wiring

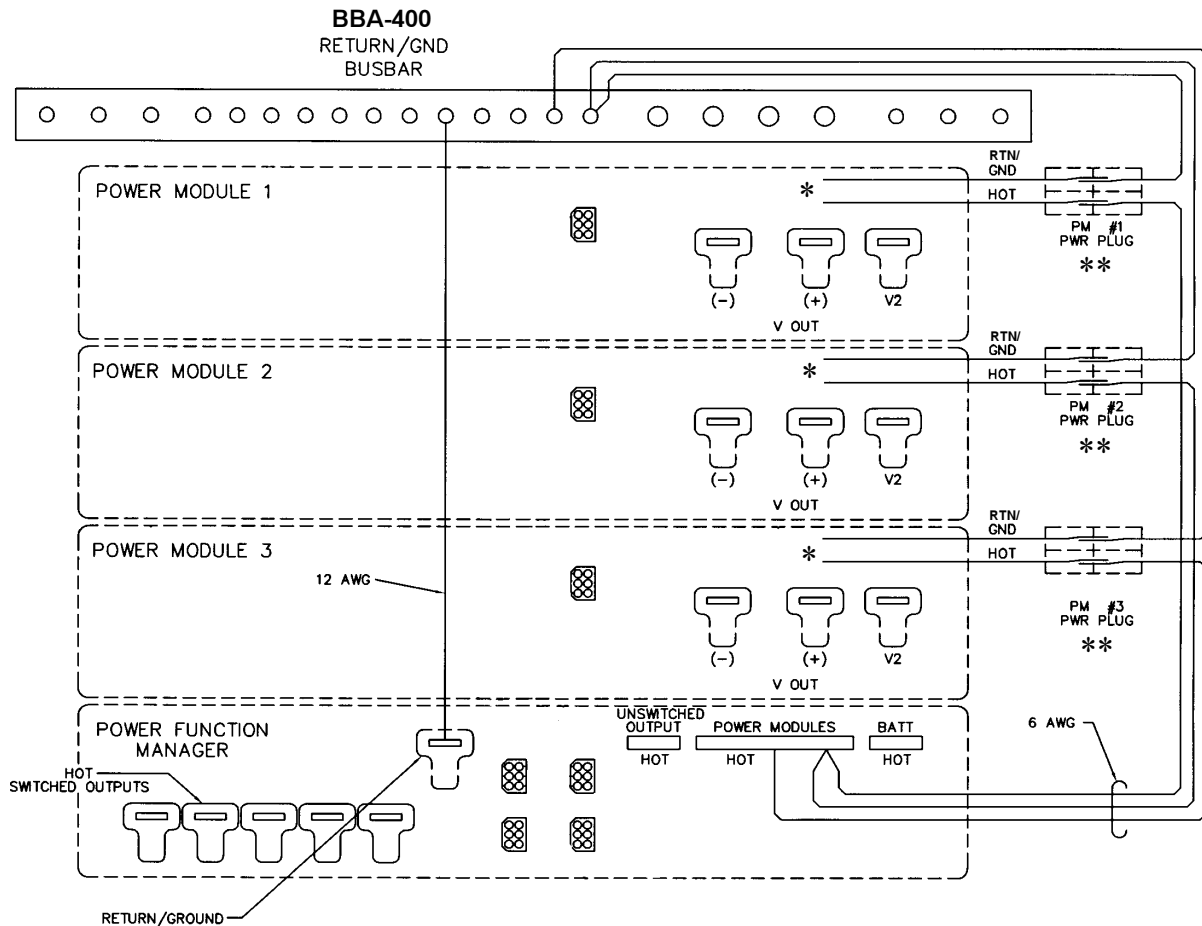

* *Negative Ground Systems: Connect Ground Wire to (-) V OUT Terminal and Hot Wire to (+) V OUT Terminal*

* *Positive Ground Systems: Connect Ground Wire to (+) V OUT Terminal and Hot Wire to (-) V OUT Terminal*

** *Power Plugs shown present only if using NEWMAR QCK d.c. Quick Connect Kit*

1) “Hot” input wires are attached to the heavy duty bus bar labeled “INPUT (POWER MODULE)” on the rear of the PFM.

This input bus bar is factory fitted with four 1/4" posts (bolt-washer-nut sets). These are removable and may be replaced with 5/16" hardware if required for the installation.

Wiring should be terminated with ring lugs to ensure a safe installation. The ring lugs

must make direct contact with the bus bar. If more than four units are wired to the PFM, lugs may be doubled up on the posts by removing the post first, then reassembling the connection so that one lug seats against the bottom of the bus bar and the other against the top. Use an additional stainless steel flat washer and lock washer set for proper installation of the second lug.

An elongated hole is provided directly behind each post to accommodate a second post for double hole wire lugs. This hole will accept either 1/4" or 5/16" hardware also and the rear post at each position is adjustable for center-to-center hole spacing between 3/4" and 1".

2) System or load ground wires are typically attached to the provided BBA bus bar, which has an assortment of hole sizes to suit most terminal requirements.

Refer to the output wiring recommendations of the instruction manual which accompanies the power modules for proper PFM input wire gauges.

3) A return/ground wire must also be run from the BBA bus bar (or other grounding point) to the post on the PFM labeled "RETURN/GND". This is not a system ground; rather, it is a reference ground for the PFM's volt/amp meter and low voltage battery disconnect. *Note: Do not confuse this post with the chassis grounding point on the left rear of the PFM.* Wiring for the return/ground wire should be 12 or 14 AWG.

Figure 3 illustrates a typical input wiring configuration with three power modules and one PFM (either positive or negative ground system). Also illustrated is a typical status and alarm wiring configuration which is discussed later.

Note: When paralleling multiple NEWMAR Power Modules, use (+) and (-) V OUT terminals only. Do not use V2 terminal.

E) Output Wiring

Output may be taken from a single unswitched output terminal or via up to five switched outputs. Installation of an optional circuit breaker (available from NEWMAR) is required for each switched output. (See section E Circuit Breaker Installation.) Refer to FIGURE 4 for the Output and Battery Wiring sections which follow.

FIGURE 4: Typical PFM d.c. Output and Battery Wiring

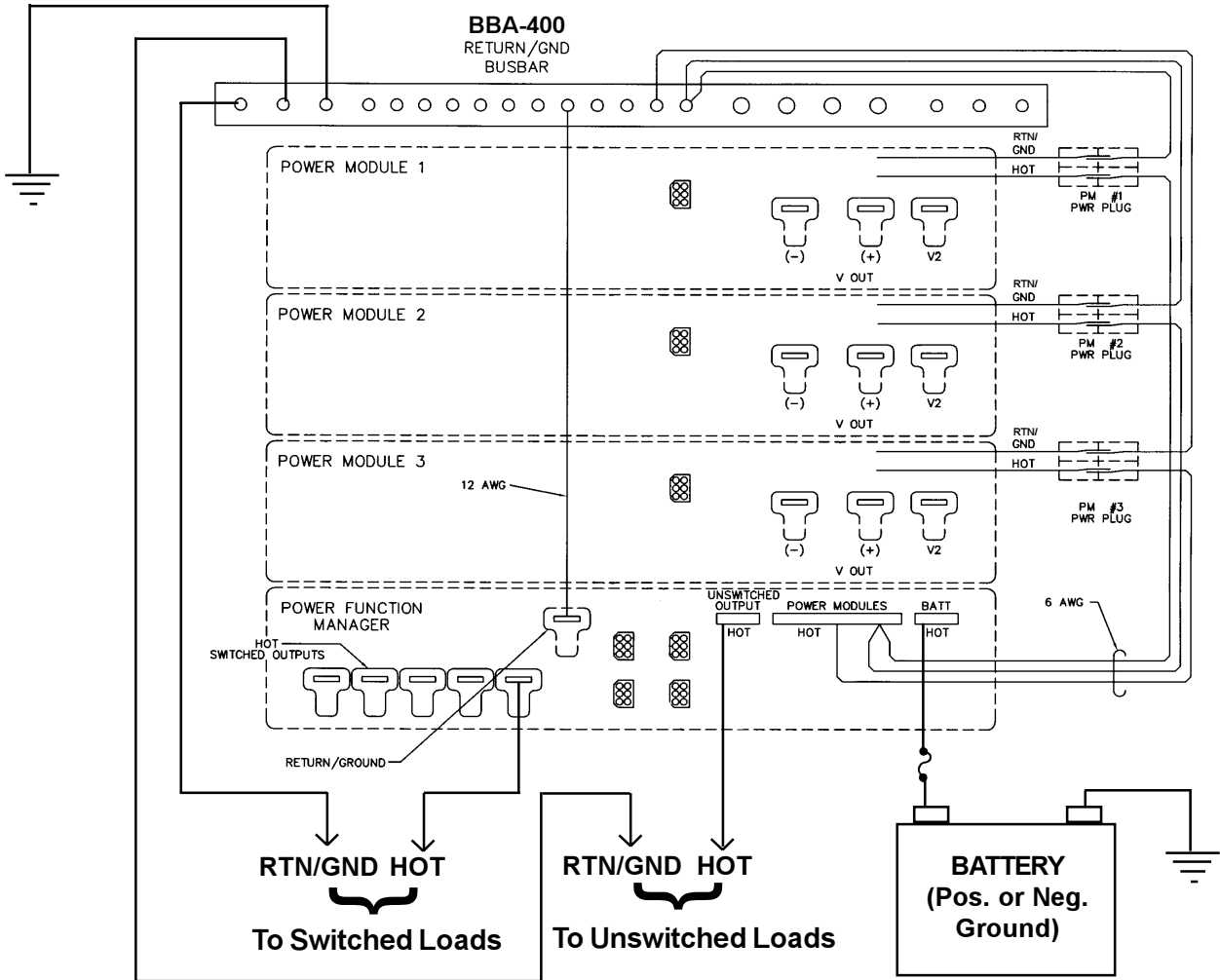

Unswitched Output

Use of the PFM unswitched output may be required under certain circumstances; for instance:

- * PFM output is routed through an external d.c. distribution panel
- * The load is in excess of 100 amps (maximum load through any switched output is 100 amps)

1) The hot load wire is attached to the post on the heavy duty bus bar labeled “UNSWITCHED OUTPUT” on the rear of the PFM.

The post hardware and bus bar hole configurations are identical to those on the “INPUT (POWER MODULE)” bus bar as described previously.

2) Use the chart below to determine minimum gauge for the output wire depending on the maximum load current and the length of the run from the PFM to the load or distribution bus (*or refer to N.E.C. or local codes for any questions regarding proper d.c. wire gauges*):

Note: Use this chart also to determine proper wire gauge for switched loads in the section following.

d.c. Wire Size Table:

<u>Output Current</u>	<u>Minimum Wire Size per N.E.C.</u>	
<u>Amps</u>	<u>AWG (mm)</u>	
up to 10	#16 (2mm)	
11-20	#14 (2.5mm)	
21-30	#12 (4 mm)	
31-35	#10 (6 mm)	
36-50	#8 (10 mm)	
51-70	#6 (16 mm)	
71-90	#4 (25 mm)	<i>Note: For applications in which a single wire will be required to carry more than 200 amps, refer to N.E.C.</i>
91-125	#2 (35 mm)	
126-150	#1 (50 mm)	
151-200	#0 (70 mm)	

To minimize line loss at lengths greater than 5 feet, it is recommended to increase wire size one gauge for each additional 5 feet of cable run.

Switched Outputs

Five switched output bus bars are provided for systems with multiple loads or where over-current protection/on-off switching at the PFM is required. Use of any of the switched outputs requires installation of a plug-in breaker (available from NEWMAR) at that position. (See section II-I for installation details and breaker functions. See section VII for available amperages and ordering guide.)

Wires are attached to the numbered output bus bars labeled “SWITCHED OUTPUTS”. Terminate wires with 1/4" ring terminals to fit the attached posts.

Before wiring loads to the switched outputs make note of the following: The conductor for each breaker position runs straight through to the rear of the PFM so that the breaker in Position 1 (as you face the front) is on the far left, and the Position 1 output terminal (as you face the rear) is on the far right, and so on with each breaker/output terminal position reversed from front to back.

Refer to the d.c. Wire Size Table above to determine proper output wire gauges.

F) Battery Wiring

1) The “HOT” (+) or (-) battery wire is attached to the heavy duty terminal labeled “BATTERY” on the rear of the PFM.

The terminal sizes and adjustability are identical to those of the “INPUT (POWER MODULE)” bus bar as described previously.

Prior to attaching battery wires ensure that the Low Voltage Battery Disconnect (LVBD) switch is in the “DISCONNECT” position. If it is not, use a ball point pen or similar object to move the recessed switch into this position. When in the disconnect position the LVBD contactor is forced open and the batteries are disconnected from the system, to ensure safe wiring. It is recommended that this switch be placed in the disconnect position whenever servicing or making or breaking any connections to the batteries.

For safety, a fuse should be installed on the hot input/output battery wire, as close to the battery as possible.

Refer to the d.c. Wire Size Table to determine proper battery wire gauges.

G) Status and Summary Alarm Contact Wiring

A color-coded status wiring harness for up to six sets of contacts has been provided with the PFM for ease of installation and to ensure proper connections. This harness is designed for installations which employ NEWMAR Power Modules, though it may be modified for use with other types of equipment, as well, provided they are equipped with Form C or Normally Open (N.O.) failure contacts.

Also provided is a color-coded six-wire “pigtail” for PFM summary alarm wiring.

All status contact connectors are for alarm inputs only and each is labeled INPUT. The summary alarm connector is for output wiring to the alarm(s) only and is labeled OUTPUT. Regardless of whether the alarm status input from the external equipment is Form C or Normally Open (N.O.) the output of the PFM summary alarm is Form C.

Refer to FIGURE 5 on the following page for the wiring instructions which follow.

FIGURE 5: Typical Status Contact and Summary Alarm Wiring

Note: This diagram depicts a system employing NEWMAR Power Modules, however, any equipment which utilizes Form C or Normally Open (N.O.) alarm contacts may be wired to the PFM's six Status Contact input connectors.

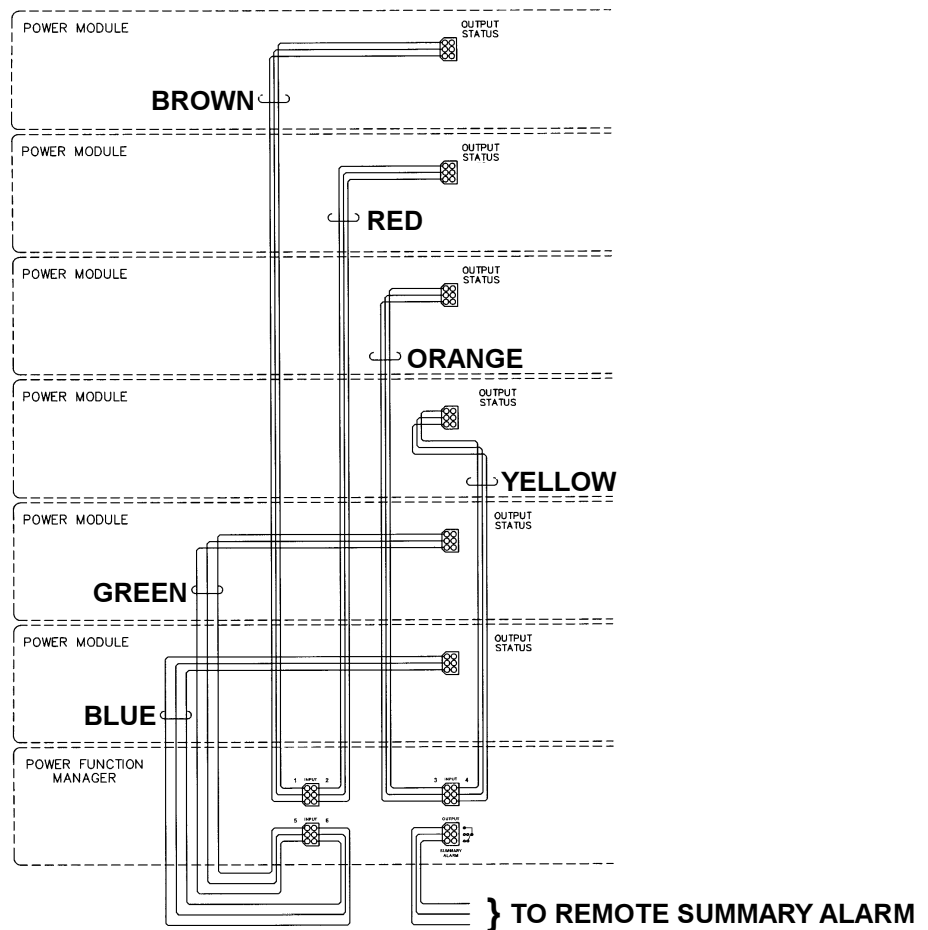

Status Contact Harness Connection

A typical system with six NEWMAR Power Modules is illustrated above. The provided status contact harness may also be used with non-NEWMAR equipment, however, it is likely that each connector on the harness which would normally plug into the power module will require removal and replacement with another suitable for that particular piece of equipment.

Careful attention to correct wire connections will be required when installing an alternate connector due to the uniform color of each wire group. Wiring from the alternate equipment contacts to the PFM contacts must be identical: fail-to-fail, OK-to-OK and common-to-common. "FAIL" and "OK" contact positions are illustrated on the rear of the unit beneath the return/ground terminal. (Or see FIGURE 6, following.)

Alarm Wiring with NEWMAR DST-20A Distribution Panel

NEWMAR's DST-20A is provided with its own four-wire harness for alarm wiring. Plug one end of the harness into the keyed connector on the rear of the DST which is labeled BREAKER STATUS. Note: The harness is reversible, therefore it does not matter which end is plugged in. Plug the other end into an unused STATUS CONTACT INPUT connector on the rear of the PFM. (Typically the #5/#6 connector will be used when Power Modules are connected to the PFM, but the summary alarm will function the same in either the #1/#2 or #3/#4 connector positions, as well.)

If all STATUS CONTACT positions are occupied (i.e., five or six Power Modules are in the system), and a summary alarm from the DST is required, this may be accomplished through parallel wiring of the status wires. Please contact the factory for information on how to perform this modification.

When wired to the PFM in this fashion any tripped breaker within the DST will result in illumination of the CHECK SYSTEM light on the front of PFM, as well as activation of the PFM summary alarm contacts.

Summary Alarm Wiring

The six-wire pigtail is provided for the remote summary alarm contacts. Only the three left-hand wires are used for this purpose. (Refer to FIGURE 6 for right/left connector orientation.) The remaining three wires may be ignored or clipped off.

The summary alarm contacts will be in the "FAIL" position under the identical conditions in which the "CHECK SYSTEM" indicator on the front panel is illuminated. (See section III-STATUS INDICATORS for a complete description of failure conditions.)

This alarm may be wired with the relay "normally open" or "normally closed", as required for the installation. The position of the contacts during d.c. output failure and normal operating condition is illustrated below:

**FIGURE 6: d.c. "FAIL" and d.c. "OK" Summary Alarm Contact Positions
(as viewed from rear of chassis)**

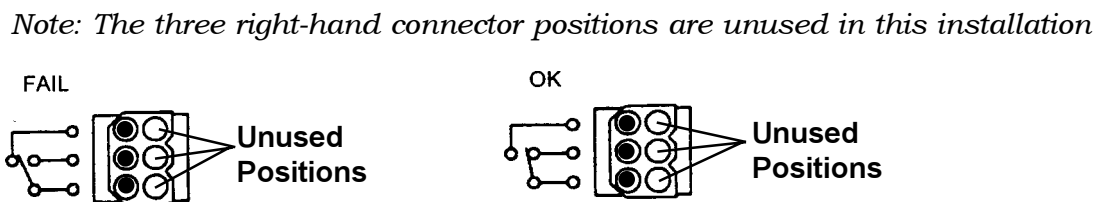

Relay contact rating for status and summary alarms is 5a @ 30V d.c.

H) Chassis Grounding

If grounding of the PFM chassis is required for the installation, use the provided 1/4" grounding stud on the rear panel identified as "CHASSIS GND" for this purpose. *Note:*

Do not confuse the chassis ground with the return ground labeled "RETURN/GND", also on the rear panel of the PFM.

I) Circuit Breakers

Circuit Breaker Installation

Circuit breakers must be installed to use any of the switched outputs. The PFM accepts only specially designed plug-in "mid-trip" circuit breakers with auxiliary contacts, which are available from NEWMAR. (The mid-trip function is explained later). Refer to the Specifications section for available breaker values and ordering info.

Refer to Figure 7 and install the plug-in circuit breakers as follows:

FIGURE 7: Circuit Breaker Installation

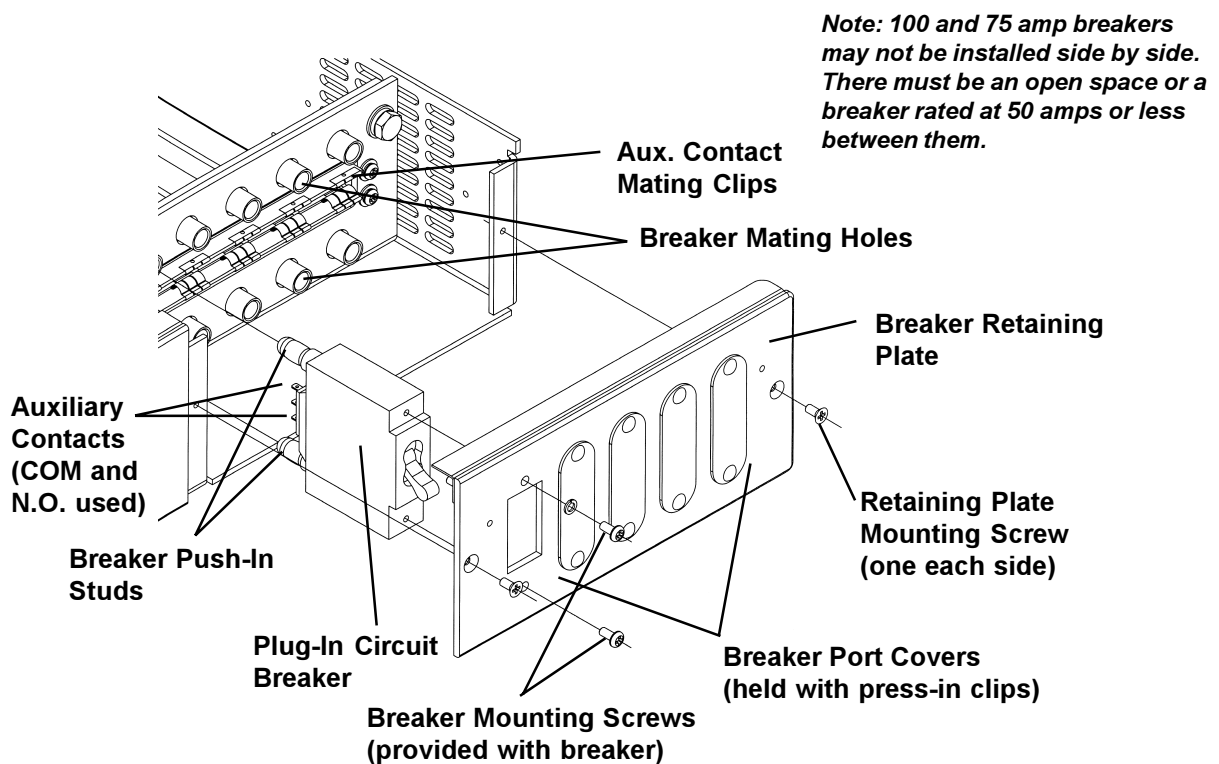

1) Shut off all power to the PFM and slide the LVBD switch on the front panel into the "DISCONNECT" position before proceeding. Remove the two flat head screws on either side of the breaker retaining plate and pull firmly outward to remove it. *Note: The protective circuit breaker cover is not shown in the above diagram.* Installation is optional. If it has already been installed, it is not necessary to remove the cover in order to remove the retaining plate. In fact, if breakers have already been installed, the cover may be used as a grip for pulling the circuit breakers and retaining plate out as a single unit (provided they are mounted to the plate).

2) Remove the plastic breaker port covers as necessary by pushing out the clips which hold them onto the plate.

3) *Prior to installing circuit breakers, make note of the following:* The conductor for each breaker position runs straight through to the rear of the PFM so that the breaker in Position 1 (as you face the front) is on the far left, and the Position 1 output terminal (as you face the rear) is on the far right, and so on with each breaker/output terminal position reversed from front to back.

Install each circuit breaker onto the breaker retaining plate with “OFF” facing upward (toggle down). *(Or see below for alternate breaker installation method).*

4) Line up the push-in studs of the breakers with the internal mating holes inside the breaker receptacle. Alternate rapping sharply on either side of the breaker/retaining plate assembly with the heel of your hand (or a rubber mallet) until it has settled firmly into place and the mounting holes are lined up.

5) Replace the retaining plate screws and restore power to the PFM (if all other aspects of installation are completed). Return the LVBD switch to the “AUTO” position.

Alternate Breaker Installation Method

After breaker retaining plate/port cover removal (steps 1-3) breaker installation may alternatively proceed as follows:

4) Install each circuit breaker into the PFM with “OFF” facing upward (toggle down) by lining up the push-in studs of the breakers with the internal mating holes inside the breaker receptacle and pushing firmly into place. The two top auxiliary contact terminals in the middle of the breaker should press against the mating clips. The bottom auxiliary contact is unused in this installation.

5) Ease the breaker retaining plate back into position over the breakers and onto the PFM. The holes in the retaining plate are beveled to help adjust the breakers into position, but it may be necessary to retract the plate and nudge breakers individually to achieve the necessary alignment.

6) Replace the retaining plate mounting screws. It is not necessary to re-install the breaker mounting screws when using this method. The retaining plate will suffice to hold them into position.

7) Restore power to the PFM (if all other aspects of installation have been completed) and return the LVBD switch to the “AUTO” position.

Circuit Breaker Cover, Labeling

Installation of the circuit breaker cover is optional. The screws for mounting the cover are already installed on either side of the breaker retaining plate. Blank labels are provided with the packaging to be placed on the cover over each position for identifying each circuit function.

Circuit Breaker Function/Mid-Trip Feature

The plug-in circuit breaker functions as an on/off switch and provides over-current protection as rated. However, the special mid-trip feature allows the operator to distinguish between a condition where the breaker has been tripped by over-current and where it has been intentionally shut off.

When the circuit breaker is manually shut off, the summary alarm contacts within the PFM will remain in the "OK" position, to avoid setting off alarms unnecessarily when disconnect is intentional. When the breaker is tripped by over-current into the mid-trip position, the toggle handle will rest mid-way between the on and off positions, the PFM "CHECK SYSTEM" light will illuminate and the Form C summary alarm contacts will be in the "FAIL" position. (See Status Indicators section following.)

IV) STATUS INDICATORS

A) Output Voltage/Current Meter

The digital meter on the front panel of the PFM may be used to monitor either system voltage (to the nearest 1/10 volt) or total power module output current (to the nearest amp). *Note: The meter does not indicate current from the battery.* Meter accuracy is 1% \pm one digit.

Simply press the push-button selector to switch between voltage and current indication. A diagram beside the switch indicates the volts/amps switch positions.

Note: When the PFM is used for positive ground applications a minus symbol (-) will appear in the meter display for both volts and amps.

B) "BATTERY ON LINE" L.E.D - Green

This L.E.D. illuminates whenever the LVBD contactor is closed. The contactor closes when the LVBD switch is in the "AUTO" position and sufficient charging voltage is sensed at the INPUT (POWER MODULE) bus bar. Consequently, if the power module is operational while the battery is disconnected (by a blown battery fuse, for instance) it is still possible for the "BATTERY ON LINE" L.E.D. to be illuminated. To confirm that battery back-up power is available when this indicator is illuminated, do one of the following:

- 1)** Move the LVBD switch to the "DISCONNECT" position and, using a multimeter, verify voltage at the BATTERY HOT post on the rear of the PFM.

- 2)** *Note: If the system is operating, this method may cause interruption of power to the loads if the battery is not connected.* Place the METER SELECT switch on the front panel in the DC VOLTAGE position and verify that the LVBD switch is in the "AUTO" position. Turn off all connected power modules and verify that the meter indicates voltage available. (The loads should continue to operate from the battery if it is connected.)

If either test reveals no voltage is present, check for a blown or missing battery fuse or a bad connection to the battery.

C) “CHECK SYSTEM” L.E.D. - Red

This L.E.D. illuminates during any of three failure conditions:

- 1)** Loss of d.c. input from one or more of the power modules wired to the PFM provided the loss of output is accompanied by a “FAIL” condition of the status contacts (i.e., the power source(s) must employ form C d.c. failure contacts which are wired to the status contacts of the PFM in order for it to indicate failure conditions).
- 2)** Either auto or manual disconnect of the battery via the Low Voltage Battery Disconnect while one or more power modules are providing d.c. power.
- 3)** An over-current condition of any installed circuit breaker which sets the toggle into the mid-trip position. (See Circuit Breaker section of this manual for an explanation of this function.)

D) LVBD “OPEN” L.E.D. - Red

This L.E.D. will illuminate during auto or manual disconnect of the battery via the Low Voltage Battery Disconnect while one or more power modules are providing d.c. power. *Note:* This L.E.D. will not illuminate if the battery is disconnected and there is no other power source to the PFM providing d.c. power. (See following section for complete explanation of LVBD circuit.)

IV) LOW VOLTAGE BATTERY DISCONNECT (LVBD)

A) Circuit Purpose

The LVBD circuit prevents battery system and/or communication equipment damage due to excessive battery discharge (typically encountered during an extended loss of a.c. power to the site) by automatically disconnecting the battery at a designated preset voltage and reconnecting the battery at another preset voltage. The disconnect and connect voltage actuation points are user-adjustable (as described below). A high current contactor opens and closes the circuit to the battery.

Note: Under most circumstances the LVBD will reconnect the battery immediately following restoration of a.c. power to the system.

If it is necessary to remove the batteries from the system for maintenance or replacement, the front panel located LVBD switch may be manually placed in the DISCONNECT position, allowing the installer to perform the service without system shutdown.

B) Actuation Voltage Adjustment

The factory set actuation voltages are as follows:

	<u>12 Volt</u>	<u>24 Volt</u>	<u>48 Volt</u>
Disconnect (OPEN)	10.4V d.c.	20.0V d.c.	40.0V d.c.
Connect (CLOSE)	12.4V d.c.	24.8V d.c.	50.0V d.c.

The connect and disconnect voltages may be adjusted $\pm 15\%$.

Access to the contactor actuation voltage potentiometers is through the front panel ports labeled "OPEN" and "CLOSE". Adjustment may be made using a small flat tip screwdriver.

Do not set the connect and disconnect voltages too close together. Rapid cycling of the LVBD may result.

Use the following procedure to adjust the actuation voltages:

- 1)** Ensure that the system voltage switch of the PFM is in the correct 12, 24 or 48V position.
- 2)** Place the LVBD slide switch in the "AUTO" position.
- 3)** Connect a variable output power supply to the INPUT (POWER MODULE) bus bar and the RETURN/GND terminal on the rear of the PFM. (Power supply output + and - polarity does not matter for this procedure.) Set the meter select switch on the front panel to the voltage position.
- 4)** Turn the "CLOSE" potentiometer fully clockwise. Turn the "OPEN" potentiometer fully counterclockwise.
- 5)** The disconnect (open) voltage must be set first. Adjust the power supply voltage until the desired disconnect voltage is indicated by the meter. Slowly turn the "OPEN" potentiometer clockwise until the red "OPEN" light illuminates and the green "BATTERY ON LINE" indicator goes out. (At the same time you should hear an audible click of the LVBD contactor opening.)
- 6)** Verify the correct disconnect voltage by turning the variable power supply up until the contactor closes, then slowly lowering supply voltage until the contactor opens. If necessary, slightly adjust the potentiometer up or down, then reverify disconnect voltage. Repeat this process until the desired disconnect voltage is achieved.
- 7)** Set the connect (close) voltage. Adjust the power supply output voltage until the desired connect voltage is indicated by the meter. Note that the "OPEN" light beneath the LVBD switch is illuminated. Slowly turn the "CLOSE" potentiometer counterclockwise until the green "BATTERY ON LINE" indicator on the front panel illuminates and the "OPEN" light goes off. (At the same time you should hear an audible click of the LVBD contactor closing.)

8) Verify the correct connect voltage by turning the variable power supply voltage down until the contactor opens, then slowly raise the supply voltage until the contactor closes. If necessary, slightly adjust the potentiometer up or down, then reverify connect voltage. Repeat this process until the desired connect voltage is achieved.

V) TROUBLESHOOTING

<u>PROBLEM</u>	<u>POSSIBLE CAUSE</u>	<u>CORRECTIVE ACTION</u>
A. "CHECK SYSTEM" L.E.D. illuminated	1. Status contacts for one or more power modules or other monitored equipmen mis-wired.	1. See section II-G for proper status contact wiring.
	2. One or more Power Modules not outputting current.	2. Verify Power Module is properly set up for available a.c. input and is wired correctly. See Power Module Installation/ Operation manual to verify proper operation.
	3. LVBD in open position. (Red "OPEN" L.E.D. illuminated and "BATTERY ON LINE" L.E.D. not illuminated.)	3a. Verify LVBD switch is in the "AUTO" position.
		3b. Check to see if battery voltage is below the LVBD disconnect threshold. If so, remove load and recharge battery.
3c. Check to see if LVBD disconnect voltage is set too high. See section IV-B for LVBD adjustment procedure.		
B. LVBD contactor rapidly cycles between open and closed	4. PFM load circuit breaker tripped. (Breaker is in mid-trip position. <i>Note:</i> Breaker will not activate the "CHECK SYSTEM" L.E.D. if manually switched into the off position.)	4. Identify cause of over-current condition and reset breaker.
	1. LVBD out of adjustment.	1. See section IV-B for LVBD adjustment procedure.

PROBLEM**POSSIBLE CAUSE****CORRECTIVE ACTION**

C. LVBD disconnects battery from load too soon-batteries not low.

1. Disconnect threshold set too high.

1. See section IV-B for LVBD adjustment procedure.

2. Large voltage drop between (+) or (-) battery terminal and BATTERY HOT input post.

2. Shorten wire length and/or increase wire size. Check for loose connections.

3. Sudden voltage drop due to heavy intermittent load.

3. Increase battery capacity or test and replace batteries if necessary.

D. LVBD will not connect battery to PFM although battery is fully charged.

1. Five amp internal circuit fuse blown.

1. Replace blown fuse. (Contact factory for instructions.) If fuse blows repeatedly contact factory for return authorization.

2. LVBD out of adjustment.

2. See section IV-B for LVBD adjustment procedure.

3. LVBD switch is in "DISCONNECT" position.

3. Reposition switch to "AUTO".

Factory Contact Information

If a problem with the PFM-400 persists after you have applied the above-outlined solutions, or if you have any questions about the installation and proper operation of the unit, please contact NEWMAR's Technical Services Manager:

Phone: 714-751-0488 — From the hours of 7:00 A.M. to 4:30 P.M. weekdays, P.S.T.

Fax: 714-957-1621 — Anytime

E-Mail: techservice@newmarpower.com — Anytime

We are happy to consult with you to resolve any problems or questions you may have. If, during consultation, it appears the PFM must be returned to the factory for repair we will issue a Return Materials Authorization at that time.

VI) SPECIFICATIONS

INPUT/OUTPUT: 12, 24 or 48V d.c. nominal (front panel selectable); Positive or Negative Ground

MAXIMUM TOTAL CURRENT CAPACITY: 400 amps (six power modules maximum)

DIGITAL METER ACCURACY: 1% ± one digit

PROTECTION:

Up to five branch circuit breakers (optional)
Low Voltage Battery Disconnect (See LVBD Specifications)

INDICATORS/ALARMS:

"BATTERY ON LINE" L.E.D. indicator (Green)
"CHECK SYSTEM" L.E.D. indicator (Red)
Digital volt/amp meter (selectable)
LVBD "OPEN" L.E.D. indicator (Red)
Form C summary alarm contacts; provide for monitoring of up to six inputs from equipment with either Form C or Normally Open contacts. Typical indications include Power Module failure, LVBD activation, breaker mid-trip condition

TEMPERATURE RATING: -40° C to +60° C

CASE SIZE: H x W x D; 3.5" x 19" or 23" x 20.5"

LVBD SPECIFICATIONS:

Factory set actuation voltages:

	<u>12 Volt</u>	<u>24 Volt</u>	<u>48 Volt</u>
Connect (CLOSE)	12.4V d.c.	24.8V d.c.	50.0V d.c.
Disconnect (OPEN)	10.4V d.c.	20.0V d.c.	40.0V d.c.

Min/Max Connect/Disconnect Voltages: User adjustable ± 15%

VII) CIRCUIT BREAKER SPECIFICATIONS AND ORDERING GUIDE

Current Ratings: See chart below (breaker value stamped beside toggle)
Voltage Rating: 80 V d.c. max.
Type: Magnetic-Hydraulic Plug-in with Auxiliary Contacts (Normally Open) and Mid-Trip Function
UL Listed Telecom Breaker
CSA Certified

To order additional or replacement breakers for the PFM-400 refer to the following NEWMAR model or Carlingswitch part numbers:

<u>Rating</u>	<u>NEWMAR Model</u>	<u>Carlingswitch P/N</u>
5 amp	PBA-5	CT1-B2-14-450-A11-MG
10 amp	PBA-10	CT1-B2-14-610-A11-MG
15 amp	PBA-15	CT1-B2-14-615-A11-MG
20 amp	PBA-20	CT1-B2-14-620-A11-MG
30 amp	PBA-30	CT1-B2-14-630-A11-MG
40 amp	PBA-40	CT1-B2-14-640-A11-MG
50 amp	PBA-50	CT1-B2-14-650-A11-MG
75 amp	PBA-75	CT1-B2-14-675-A11-MG
100 amp	PBA-100	CT1-B2-14-810-A11-MG

Note: Other circuit breaker values are available on a special order basis. Typical lead time is 10 weeks.