

Emergency Vehicle Battery Charger

Model: EV-40

Installation/Operation Manual



Table of Contents

Section Topic	Page
QUICK REFERENCE DRAWING.....	2
I) GENERAL INFORMATION.....	3
II) IMPORTANT SAFETY INFORMATION.....	3
III) INSTALLATION.....	4
A) Materials Provided.....	4
B) Location.....	4
C) Mounting.....	5
D) DC Output Wiring, Battery & Auxiliary Loads.....	5
E) AC Input Wiring.....	7
IV) OPERATION.....	7
A) Three Stage Charge Regimen.....	7
B) Time-Out Circuit.....	8
C) Gel-Cell/AGM/Lead-Acid Selector Switch.....	8
D) Remote Monitor Panel Option.....	8
E) Cooling Fan.....	8
F) Power-On Indicators.....	9
V) APPLICATION NOTES.....	9
A) Start Up.....	9
B) Constant Versus Occasional Use.....	9
C) Proper Load Sizing.....	9
D) Operation with Engine.....	10
E) Operation as a DC Power Supply (stand-alone DC power source).....	10
VI) SPECIFICATIONS.....	10
VII) TROUBLESHOOTING.....	11
VIII) BATTERY CARE TIPS.....	13
UNIT DIMENSION DRAWING.....	14



DC Power Onboard
Emergency & Specialty Vehicles

M-EV40
As of September 2010

Quick Reference Drawing: EV-40

AC Plug Input Socket (IEC) Modular Plug, Cord Provided; Pg. 7

Auxiliary Output Selector Switch:
A) powered only when AC shore power connected (battery saver mode), B) continuously connected to vehicle battery; **Pg. 6**

Battery Type Selector Switch (Gel-Cell/Lead-Acid/AGM); Pg. 8

Remote Meter Plug-in Connector; Pg. 8

AC Power Indicator Light (Green); Pg. 9

DC Output Indicator Light (Green); Pg. 9

Battery Output Connector Block - 40 Amps Maximum; Pg. 5

Auxiliary Output Indicator Light OK (Green); Pg. 9

Auxiliary Output Connector Block - 15 Amps Maximum (Air Pump, Hand Lights, Radios); Pg. 5

Optional Accessories

Protective Front Panel Kick Plate (Optional); Pg. 5

Remote Meter, EVM-12-1 (Optional); Pg. 8

Slide-in and Lock Mounting Plate (optional); Pg. 5

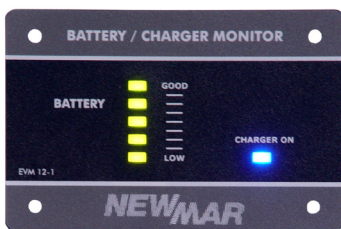

DC Power Onboard
Emergency & Specialty Vehicles

1) General Information

The EV™ Series Battery Charger represents a new phase in charger design and performance. It's ideal for application on emergency and specialty vehicles, utilizing "smart" switching circuitry which puts batteries through the optimum three-stage charge process, adapts for gel-cell, AGM or lead-acid batteries, is rated for continuous duty and is housed in an aluminum case with an optional slide-in front access installation bracket.

Following is a brief listing of some of the more important features/options. Each is fully detailed later in this manual:

- Three step "smart" charging: bulk, absorption, float
- Gel-Cell/AGM/Lead-Acid switch selects optimum charge/float voltages based on battery type
- 90-264VAC, 50-60 Hz input – can be used anywhere in the world
- Current limited – prevents damage in case of overloading
- Thermally controlled cooling fan allows continuous operation at full-rated output
- High charge voltage time-out circuit prevents overcharging during continuous high amperage demand
- Optional Remote Panel allows remote monitoring of charger status
- Use as a power supply without in-line battery; allows continued use of DC powered electronics (when AC is available) in the event that batteries must be taken off-line or removed
- Auxiliary output for electronics, air compressors, and hand lights

II) Important Safety Instructions

1. SAVE THESE INSTRUCTIONS – This manual contains important safety and operating instructions for the EV-40 Battery Charger.
2. Before using this battery charger, read all instructions and cautionary markings on (1) the battery charger, (2) the battery, and (3) product powered by the battery.
3. CAUTION – To reduce the risk of injury, charge only 6 cell (12 volt models) gel-cell or lead-acid rechargeable batteries. Other types of batteries may burst, causing personal injury and damage.
4. Do not expose charger to rain or spray.
5. Use of an attachment not recommended or sold by NEWMAR may result in a risk of fire, electric shock or injury to persons.
6. To reduce the risk of damage to the electric plug and cord (if plugged into an AC outlet), pull by plug rather than cord when disconnecting the charger.

7. Make sure the cord is located so that it will not be stepped on, tripped over, or otherwise subjected to damage or stress.

8. An extension cord should not be used unless absolutely necessary. Use of an improper cord could result in the risk of fire and electric shock. If an extension cord must be used, make sure:

A) That pins on the plug of the extension cord are the same number, size and shape as those on the plug of the charger.

B) That the extension cord is properly wired and in good electrical condition.

C) That the wire size is large enough for the AC amperage rating of the charger. Refer to the **SPECIFICATIONS** Section, page 10, to determine the full load input current of your charger, and then use the chart below to determine the correct gauge wire for any extension cord used.

RECOMMENDED MINIMUM AWG SIZE FOR EXTENSION CORDS FOR EV BATTERY CHARGER			
Length of Cord, Feet			
25	50	100	150
Size of Cord, AWG			
16	14	12	10

9. Do not operate the charger with a damaged cord or plug; replace them immediately.

10. Do not operate the charger if it has received a sharp blow, been dropped, or otherwise damaged; take to a qualified serviceman.

11. Do not disassemble the charger; take it to a qualified serviceman when service or repair is necessary. Incorrect reassembly may result in a risk of electric shock and fire.

12. To reduce the risk of electric shock, disconnect the charger from AC source before attempting any maintenance or cleaning.

WARNING – RISK OF EXPLOSIVE GASES

1. WORKING IN THE VICINITY OF A LEAD-ACID BATTERY IS DANGEROUS. BATTERIES GENERATE EXPLOSIVE GASES DURING NORMAL BATTERY OPERATION. FOR THIS REASON, IT IS OF THE UTMOST IMPORTANCE THAT BEFORE INSTALLING AND USING YOUR CHARGER, READ THIS MANUAL AND FOLLOW THE INSTRUCTIONS EXACTLY.

NEWMAR[®]

DC Power Onboard
Emergency & Specialty Vehicles

www.newmarEVpower.com

2. To reduce the risk of battery explosion, follow these instructions and those published by the battery manufacturer and by the manufacturer of any equipment you intend to use in the vicinity of the battery. Review cautionary markings on these products and on the engine.

PERSONAL PRECAUTIONS

1. Someone should be within range of your voice or close enough to come to your aid when you work near a lead-acid battery.
2. Have plenty of fresh water and soap nearby in case battery acid contacts skin, clothing, or eyes.
3. Wear complete eye and clothing protection. Avoid touching your eyes while working near a battery.
4. If battery acid contacts skin or clothing, wash immediately with soap and water. If battery acid enters the eye, immediately flood eye with running cold water for at least 10 minutes and get medical attention immediately.
5. NEVER smoke or allow a spark or flame in the vicinity of the battery or engine.
6. Be extra cautious to reduce the risk of dropping a metal tool onto the battery. It might spark or short-circuit the battery or other electrical part and cause an explosion.
7. Remove personal metal items such as rings, bracelets, necklaces, and watches when working with a lead-acid battery. A lead-acid battery can produce a short-circuit high enough to weld a ring or the like metal, causing a severe burn.
8. Use the battery charger for charging gel-cell or flooded lead-acid batteries only. It is not intended to supply power to a low voltage electrical system other than in a starter-motor application. Do not use the charger for charging dry-cell batteries that are commonly used with home applications. These batteries may burst and cause injury to persons and damage to property.
9. NEVER charge a frozen battery.

PREPARING TO CHARGE

1. Be sure the area around the battery is well ventilated.
2. Clean battery terminals. Be careful to keep corrosion from coming in contact with eyes.
3. Add distilled water in each cell until battery acid reaches level specified by battery manufacturer. This helps purge excessive gas from cells. Do not overfill. For a battery without cell caps, carefully follow manufacturer's

recharging instructions.

4. Study all battery manufacturers' specific precautions such as removing or not removing cell caps while charging and recommended rates of charge.

GROUND AND AC POWER CORD CONNECTION

1. The charger should be grounded to reduce risk of electrical shock.
2. The Charger is provided with IEC certified AC power cord. If, for any reason, the plug on the cord must be changed or replaced, observe color coding of the AC wiring as follows:

Black.....AC Hot (fused)
White.....AC Neutral
Green.....AC Ground (safety/earth)

The charger must be plugged or hard wired into an outlet that is properly installed and grounded in accordance with all local codes and ordinances.

DANGER: Never alter the AC cord or plug provided, unless it is absolutely necessary for use with the AC outlet which conforms to all relevant electrical codes. Any modification of the cord must only be done by a qualified electrician. Improper cord/outlet connection can result in a risk of electrical shock.

EXTERNAL CONNECTIONS TO THE CHARGER SHALL COMPLY WITH UL RECOMMENDATIONS, NEC, or NFPA STANDARDS

III) INSTALLATION

A) Materials Provided

The charger is provided completely assembled and ready for installation. Because of numerous installation variables, the installer will need to provide four suitable 1/4" mounting screws/washers, as well as DC output wiring and battery connectors. Proper sizes and gauges for the wire and connectors are noted in **Section III-D** following.

B) Location

The charger should be mounted on a wall, vehicle floor, ventilated compartment or other suitable surface as close to the batteries to be charged as possible. Do not mount the charger directly over the batteries as fumes may cause excessive corrosion. The area should be well ventilated and free from excessive moisture, exhaust manifolds, and battery fumes.

For maximum performance, the charger should not be located in an area of extreme high temperature.



DC Power Onboard
Emergency & Specialty Vehicles

www.newmarEVpower.com

IMPORTANT: Although the charger is constructed of materials and in a manner which make it highly resistive to the corrosive effects of moisture in the environment, the charger is not waterproof. Do not mount the charger where there is a possibility of water entering the unit. Evidence of water entry into the charger will void the warranty.

C) Mounting

Charger only (not using optional Slide-in Bracket Assembly.)

The charger may be mounted on either a metal or non-metal surface. You will require four (4) screws (wood or machine screws, depending on mounting surface) with washers, sized for 1/4" holes, located on the tab end panel. For extreme vibration installations, use optional High-Vibe Mounting Kit (model Kit-L).

Optional Slide-In Bracket

For installation in hard to access locations such as under a seat or in storage compartments, an optional "slide-in" bracket assembly is available (P/N: 444-52790-0), which permits total front access only removal and re-installation. The system consists of a base mounting plate which is secured to the vehicle, and a slide plate which attaches to the bottom plate of the battery charger. This slide plate has pins that slide in and engage with the base mounting and are secured in place by front panel screws. The slide-in plate can be oriented to the rear of the assembly or facing out, at installers discretion. Reference **Figure 2**.

Figure 2: Optional Slide-In Bracket

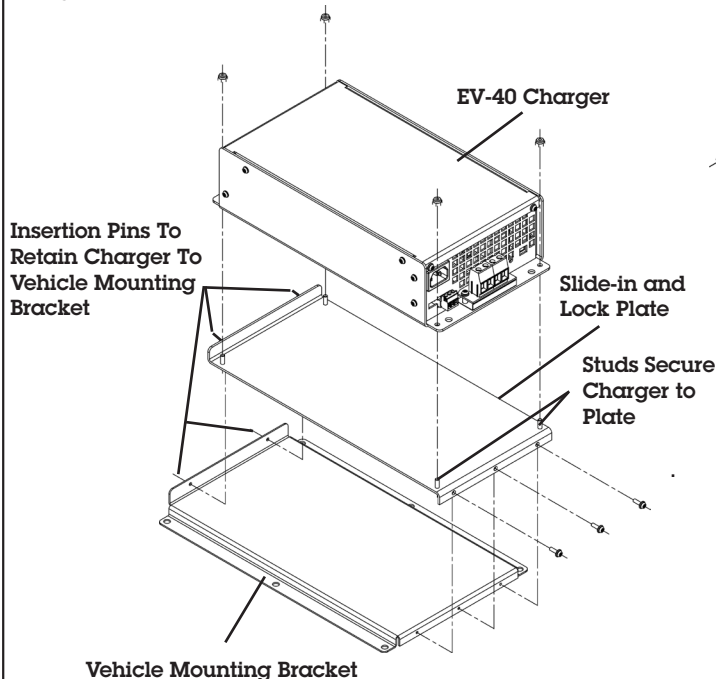

Slide-in and Lock Mounting System Description

The Slide-in and Lock mounting plate system is designed to ease installation and removal of the EV-40 charger in hard to access areas such as under seats and in small compartments:

- Charger is secured to the slide-in and lock plate via 4 stud mounts.
- **Note charger can be oriented either direction on the plate to meet desired location of front panel wiring.**
- The Vehicle mounting bracket is secured in its desired location via 6 fasteners.
- Charger with plate attached the slides on to the vehicle mounting bracket and is captured via two insertion pins at one end and secured in place via stainless steel fasteners and compression angle bracket at other end.

Kick Plate

To protect wiring on the charger end panel, an optional Kick Plate is available, (P/N: 444-5280-0)

It installs using the front end panel screws. Loosen the two (2) screws shown in **Figure 3**, and attach the kick plate to the battery charger case. Re-tighten screws.

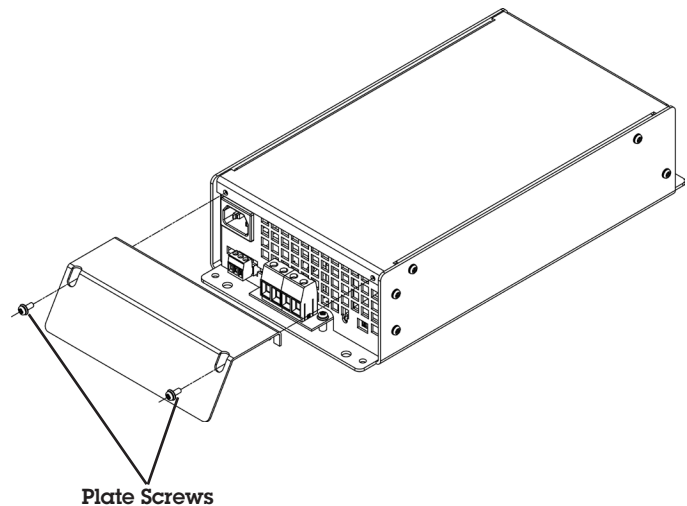

D) DC Output Wiring To Battery

Secure battery wiring to the output terminal block observing proper polarity and wire gauge per the table on the following page. Strip wires 1/2", insert in barrel terminal and secure in place by tightening the screw. Note, wire terminals are not necessary. See **Figure 4**.



DC Power Onboard
Emergency & Specialty Vehicles

www.newmarEVpower.com

The DC wire size table below may be used to determine the correct gauge wire, based the length of the wire run from the charger to the batteries.

DC Wire Size Table			
Model	Distance from Batteries, Feet		
	10	15	20
Wire Gauge AWG (mm)			
EV-40	#8 (10mm)	#8 (10mm)	#6 (16mm)
*Based on 10% voltage drop table and NEC minimum wire size charge			

Note: If batteries are closer to charger than battery switch, wire directly to battery posts.

It is recommended that DC wiring from the charger to the batteries be as direct as possible. Line voltage loss and electronic noise interference of sensitive electronics are possible if the charging leads are routed through a central electrical distribution panel.

ENSURE THAT LEADS ARE PROPERLY FUSED AT THE BATTERY.

Ensure that your connections are tight and that correct polarity is carefully observed at all times. The battery posts should be free of any rust or corrosion.

IMPORTANT NOTE: EVEN MOMENTARY REVERSE POLARITY CONNECTION MAY SEVERELY DAMAGE YOUR CHARGER. THE POSITIVE (+) TERMINAL MUST BE WIRED TO THE POSITIVE POST OF THE BATTERY AND THE NEGATIVE OR COMMON (-) TEMINAL TO THE NEGATIVE POST OF THE BATTERY OR COMMON BUS.

CAUTION: Do not attempt to increase battery bank capacity by splitting the output of one of the banks with a diode-type battery isolator. Undercharging may occur on the output bank, as a result. If you wish to add another isolated battery bank, use of NEWMAR's Battery Integrator is recommended. Contact the factory for details.

An important Note about the DC Output Fuse(s): internal DC wiring is protected by the internal DC output fuse(s). The current limiting circuit of the charger should prevent these fuses from blowing under normal operating conditions. If the DC fuse(s) blow, this may indicate a reverse polarity hook-up or an internal short.

Always disconnect AC to the charger before checking fuses. To check or replace the DC fuse, the cover must be removed. To do this requires removal of two screws from the front of the unit and five screws on each side. The DC fuse is mounted on the main circuit board. Be sure to replace with the same type and value as indicated on the fuse.

If the battery was connected to the charger backwards, the fuse should blow to protect DC wiring, however; damage to internal components may also have occurred. If the replacement fuse blows, return the charger to an electronics service professional or to the factory for a thorough inspection. **Note:** The internal fuses do not provide protection if there is a short in the wiring between the charger and the battery. The battery is itself a power source and charging leads should be fused at the battery.

Auxiliary Output

As shown in **Figure 4**, there are two terminals on the output connection block labeled auxiliary +/- . This output is intended for auxiliary loads such as air pumps, electronics, and hand lights, and is rated at 15 amps. Installer has the option, via a front panel selector switch, of powering the auxiliary output only when the AC is applied to the charger (switch position A), thus never discharging the battery directly, or alternatively, allowing the auxiliary circuit to be powered all the time from the vehicle battery, regardless of whether the charger is operating or not (switch position B). Note that in position "B", if the charger is not operating for an extended period of time or the engine alternator not running, the auxiliary loads will eventually drain the vehicle battery.

The auxiliary output circuit is protected by an auto-resetting circuit breaker, so if the auxiliary loads exceeds 15 amps, the breaker will cycle on and off. A front panel LED is wired to this breaker and will extinguish when power is not available at the aux circuit terminals.

Figure 4: DC Output Wiring

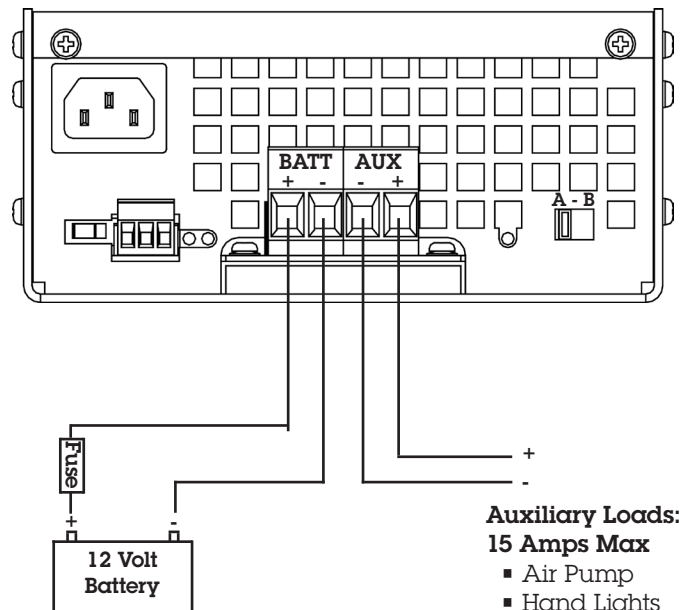

- Auxiliary Loads:
15 Amps Max**
- Air Pump
 - Hand Lights
 - Electronics

Note: Output Fuse Size Recommended 125-150% of Cable Ampacity.



DC Power Onboard
Emergency & Specialty Vehicles

www.newmarEVpower.com

E) AC Input Wiring

An IEC certified 3 foot AC cord is provided that plugs into the charger and a proper outlet. If the plug is not suited to the available outlet, 1) obtain an IEC cord with appropriate plug or 2) obtain the correct plug for the outlet and install it on the provided IEC cord. When installing the plug, pay careful attention to the pin wiring as follows:

Black.....AC Hot (fused)
white.....AC Neutral
GreenAC Ground (safety/earth)

The charger will operate on 90-264 VAC input-No selectors with setting required

A power cord cable clamp has been provided to prevent accidental disconnect of the AC cord. After the plug has been inserted into the charger, snap the pre-formed clamp around the AC input cable as close to the insertion point as practicable and use a screw to fasten the clamp tightly to the surface on which the charger is mounted..

Hard-wiring AC Input

If desired, the AC input to your charger may be hard-wired directly to the AC distribution panel or junction box. Install the charger end of the provided input cord as described above, then cut off the plug and splice onto three conductor marine-grade cable with crimp butt connectors, observing color codes and fuse/circuit breaker ratings as above. Use minimum 16 AWG cable.

AC input for the charger must be plugged into an appropriate, over-current protected three prong outlet OR routed through a separate dedicated fuse or circuit breaker on an AC distribution panel with proper safety/earth chassis ground in accordance with all local codes and ordinances.

CAUTION (230 VAC applications only): If AC input is derived from a source consisting of two HOT leads (phase-to-phase 230 VAC input voltage), an external fuse or circuit breaker must be used to protect the unfused (formerly NEUTRAL, now HOT) lead.

Input Fuse Replacement - The AC input of your charger is protected by an internal input fuse. This indicates the charger has an internal short, return the charger for service.

IV) OPERATION

A) Three Stage Charge Regimen

The Battery Charger features the three stage charge regimen which is widely recommended by battery manufacturers for allowing the fastest possible recharge

time without loss of batteries' electrolyte (gel or liquid) which may be caused by sustained charging at higher voltages.

This three stage regimen is initiated each time AC is first applied, when drained batteries are most likely to be encountered.

1) Bulk Charge—When batteries are significantly discharged the charger responds initially by delivering a high amount of DC current, at or near the charger's maximum rated output, in order to rapidly replenish them. It is during this stage that charging current is maintained at a high level as battery voltage increases. Bulk charging continues until battery voltage reached the "charge" voltage level (where batteries are at about 75-80% of capacity). A current limit circuit prevents charger overload during this maximum output stage

2) Absorption Charge – During this second stage of the charge cycle, battery voltage is maintained at the "charge" voltage level. Output current begins to taper off as the battery plates become saturated. Charge voltage is maintained until the current sensing circuit detects that output current has tapered to about 5-15% of charger rating*. At this point, the batteries are at about 95% of full charge and the charger switches to the third and final stage of the charge cycle.

*Note: The absorption phase may also be ended by the time-out circuit. See **Section B** following for a complete explanation of the purpose and functioning of the time-out circuit.

3) Float Charge – For extended battery life, the Phase Three then automatically switches to a lower float voltage level. This float charge keeps batteries at peak condition without overcharging. The charger may be left in this stage for months without attention (though periodic checks of electrolyte level in flooded batteries is recommended.)

FIGURE 3: Typical Charger Output Graph (into battery without load)

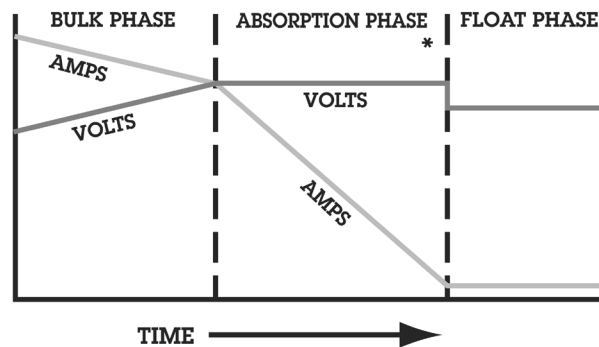

* Approximately 10 hours maximum

NEWMAR[®]

DC Power Onboard
Emergency & Specialty Vehicles

www.newmarEVpower.com

B) Time-Out Circuit

Batteries have a tendency to lose their electrolyte and may be damaged if they are maintained for long periods of time in the elevated voltage of the absorption phase. Therefore, the Phase Three Charger employs a special time-out circuit. This circuit is initialized each time AC is first applied to the charger (or when the re-initialize button on the optional remote panel is activated) and runs for a pre-set interval before forcing the charger to go into the float (lower voltage) mode. The functioning of the charger during this interval is as follows:

If the current demand of the batteries/load falls below 5 AMPS to the circuit timing-out, the charger will automatically switch to the float mode. If demand rises to about 8-10 AMPS, the charger will return to the elevated output of the absorption phase. This switching back and forth between modes may occur until the circuit times-out (8-10 hours after AC is first applied), after which the charger will remain at float voltage, until the circuit is re-initialized, either by turning the charger off and then on again.

Note: The Charger is able to deliver its full rated output current while in float mode.

C) Gel-Cell/AGM/Lead Acid Battery Type Selector Switch

According to most battery manufacturers, the ideal charging regimen for gel-cell, AGM, and wet or flooded lead acid batteries differs somewhat.

The gelled electrolyte in a sealed battery may be lost or damaged by high voltage and, once lost, cannot be replaced as it can with a wet lead acid battery. Manufacturers of gel-cells usually recommend an ideal charge voltage which is slightly lower than a lead acid battery.

However, when the charger is in the float voltage mode over lengthier periods of time, gelled electrolyte in a sealed battery is not susceptible to evaporation, as is the non-immobilized electrolyte of a wet lead acid battery. Thus evaporation can be accelerated by the applied voltage. Consequently, the ideal float voltage is slightly higher for a gel-cell than a lead acid battery.

The ideal charge/float regimen has been programmed into the Charger for either sealed gel-cell or flooded lead acid batteries. Simply make the proper selection for your battery type via the slide switch on the left side of the front panel. The switch positions are indicated on the front panel (left Gel-Cell batteries, and right for Lead-Acid/AGM type batteries). Use a ball point pen or small screwdriver to slide it into the correct position. **The charger is shipped from the factory set for Lead-Acid/AGM batteries.** Reference **Figure 5**.

Note: A wide variety of batteries are available which do not conform to conventional descriptions as "gel-cell" or "lead-acid". You are advised to consult the manufacturer of your particular battery as to proper charging regimen, and use the battery type selection switch setting which most closely conforms to the recommended voltages.

See the **SPECIFICATIONS Section**, page 10, for the preset charge and float voltages.

Figure 5: Battery Type Selector Switch/Remote Panel Connector

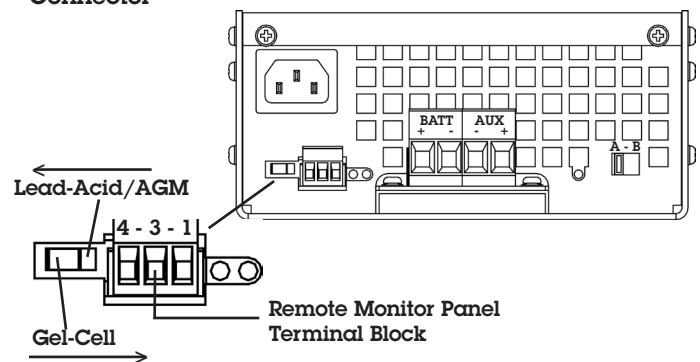

D) Remote Monitor Panel Option

A Remote Monitor Panel is available from NEWMAR (EVM-12-1) which will enable you to monitor the battery status at-a-glance from a remote location.

Model EVM-12-1 is a single battery bank charge status indicator panel that is wired to the 'remote panel' terminal block on lower left of the wiring panel. See **Figure 5**. A 3 wire connection is required for the meter, 22 AWG wire or larger. The terminal block on the charger accepts a plug-in connector that is provided in the parts bag with the unit. The numbers '4-3-1' printed on the top panel of the charger coincide with the terminals on the remote monitor terminal block on the charger front panel. See instructions provided with the EVM panel for further installation details.

Remote digital meter option is also available - specify NEWMAR model DCV. Connect + to terminal 1 and - to terminal 3.

Remote Monitor TB Pin-outs

- #1 - BATT (+)
- #3 - BATT (-)
- #4 - Charger-On

E) Cooling Fan

To maximize the life of the internal components and to allow continuous operation at full rating, the Charger employs an integral cooling fan. The fan draws air through the front of the unit and expels it out the rear to improve cooling. The fan operates whenever load and/or ambient temperature

NEWMAR[®]

DC Power Onboard
Emergency & Specialty Vehicles

www.newmarEVpower.com

cause a rise in the internal heat sink temperature. Its speed automatically increases/decreases in response to load and/or ambient temperature increases/decreases.

Note: Under most circumstances, the fan will be in operation when the charger is on.

F) Indicator LED's

There are three LED indicators on the front panel of the EV-40 charger, reference **Figure 6**.

- **AC OK** - Green, indicates AC voltage is reaching the charger, note this light will still illuminate if the unit's internal AC fuse has blown
- **DC OK** - Green, indicates DC power being produced by the charger
- **AUX POWER OK** - Green, indicates DC voltage applied to Auxiliary output terminal block. If this light cycles on and off, this indicates the circuit is over loaded and the internal self resetting circuit breaker is cycling, in which case you will need to reduce the load on the auxiliary circuit.

See **TROUBLESHOOTING Section VII**, for additional details on the indicator light operation.

Figure 6: LED Indicators

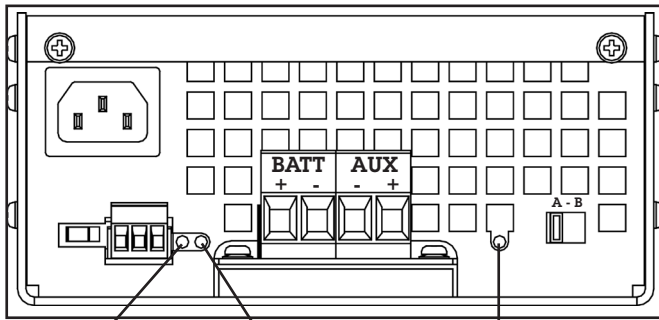

AC Power Indicator Light (Green)

DC Output OK (Green)

AUX Output Indicator Light (Green)

V) Application Notes

A) Start Up

1) Before powering up your charger, check for tight electrical connections to each battery in your system. Switch off any DC loads on the batteries. Apply AC power.

2) Apply a load to the charger by switching on some lights, or some other DC appliance. While current is demanded from the battery system, the charger will automatically increase its output in response to the increased load demand. When

load current exceeds 10-20% of the charger's rated capacity, the charger will go into the absorption mode and remain there until current drops below 5-15% of capacity or until the time-out circuit cycle is complete.

Note: The EV-40 charger is self-limiting and will rarely blow an input fuse. If the input fuse should blow upon first application of power, disconnect AC power to the charger and consult the **TROUBLESHOOTING** Section VII of this manual.

If the input fuse does need replacing, be sure to replace it with the same type and value for continued protection.

B) Constant Versus Occasional Use

In general, it is recommended that the charger be left connected continuously to the AC distribution system so that it will be in operation whenever AC is available. This will maintain batteries at peak voltage and will automatically compensate for the natural self-discharge of the battery system. When a load is applied to the battery system, the charger's output will automatically increase to supply the current which would otherwise draw battery voltage down. **Repeatedly allowing batteries to become completely discharged before recharging will greatly shorten their life. Leaving the charger on continuously will prevent this.**

While the output regulation of the charger will minimize battery gassing and water loss, monthly checks of the electrolyte level (for wet lead acid batteries) are still strongly recommended. Some water loss is an inevitable aspect of the charging process, and maintaining the correct electrolyte level in your batteries is the most important you can do to assure their maximum performance and long life.

C) Proper Load Sizing

The Charger is rated for continuous duty (e.g., the EV-40 can deliver up to 40 amps continuously). While the charger cannot be damaged by overloads that exceed this continuous rating, excessive load demands may draw battery voltage down faster than the charger can resupply it. If the battery voltage continues to drop and the output current is at maximum while the charger is in service, check to see that your average DC loads are not exceeding the charger's rated output. If they are, you may wish to consider adding another charger in parallel to provide sufficient power for your requirements.

D) Operation with Engine

It is perfectly acceptable to allow the charger to remain on when the engine is started and while it is running. The current limit feature of the Charger will protect against any damage due to the high current demands of the engine cranking.

NEWMAR[®]

DC Power Onboard
Emergency & Specialty Vehicles

www.newmarEVpower.com

As the alternator starts to charge the battery, the charger output will decrease. When the battery voltage exceeds the rated output voltage of the charger, no current will flow from the charger as long as the batteries are in this high state of charge.

E) Operation as a DC Power Supply (stand alone DC Power Source)

Most battery chargers are not suitable for powering electronic devices directly, without a battery attached to the output, as the high ripple and pulsing DC output (i.e., rectified AC output) can interfere with the operation of the device. The EV charger is different. It employs a circuit that produces an extremely well-filtered DC output. Therefore the charger is able to power virtually any DC powered device (within the unit's rating) without the battery attached in-line (if, for instance, the battery must be removed for any purpose and AC is still available). All but the most sensitive DC powered electronic devices will function as normally as if powered by a battery. In addition, the current limiting circuitry enables the charger to handle the high start-up surges associated with inductive loads, such as DC motors.

VII) Specifications

INPUT RANGE (ALL MODELS): 90-264; 47-63 HZ (automatic)

Model	Input Amps 115/230V	Output	
		Volts	Amps (Cont)
EV-40	6.8/3.4	12	40

OUTPUT VOLTAGES:

EV-40 Battery Charger		
Setting	Charge @ 50% Load	Float @ .1 Amp Load
Gel-Cell	14.0V DC	13.6V DC
Lead-Acid/AGM	14.2V DC	13.4V DC

Temperature Ratings: -20° C to + 60° C; Derate linearly from 100% @ 50° C to 60% @ 60° C

INPUT/OUTPUT FUSE VALUES:

Model	DC Output Fuse
EV-40	ATC-30 (2 each)

Case Size/Weight: 3.12" H x 6.8" W x 13.12" D; 7 Lbs.
7.92 x 17.27 x 33.32 (cm); 3.2 Kgs.

Mounting Dimensions: See page 13

PROTECTION FEATURES:

Input Fuse; Output fuse for reverse polarity protection; Current limiting; Time and load controlled high rate charge circuit; Ignition protected; IP 21

Compliances:

Safety: EN60335-1
EMC: IEC 1000-4-2,
EN55014



DC Power Onboard
Emergency & Specialty Vehicles

www.newmarEVpower.com

VII) Troubleshooting

Condition	Possible Cause	Solution
<p>A) Batteries are not coming up to full charge.</p>	<p>1) Extremely discharged batteries requiring long recharge time.</p> <p>2) Charger limiting its output due to overload or over temperature conditions.</p> <p>3) Fan not operating properly causing charger to protect against overheating.</p>	<p>1) Turn off all D.C. loads and allow charger 24-48 hours to recharge batteries. See section IV-B for explanation of time-out circuit.</p> <p>2) Reduce D.C. load and/or determine cause of over temperature state (See section III-B, "Location").</p> <p>3) Return for analysis/repair by servicing dealer where charger was purchased or contact NEWMAR for a Return Materials Authorization number.</p>
<p>B) Charger does not charge. No DC "OK" light</p>	<p>1) Charger is not receiving AC input voltage or is not receiving correct AC input voltage.</p> <p>2) Charger output is not properly connected to batteries.</p> <p>3) Blown output fuse.</p> <p>4) Defective charger.</p>	<p>1) Using a voltmeter, confirm, AC input voltage, check input connections. Confirm AC input select switch is in correct position or correct AC connector/adaptor is installed</p> <p>2) Refer to DC wiring installation diagram for proper connections to batteries.</p> <p>3) Replace with another of correct value (see section III-D, "DC Output Wiring").</p> <p>4) Return for analysis/repair by servicing dealer where charger was purchased or contact NEWMAR for a Return Materials Authorization number.</p>
<p>C) Charger repeatedly blows input fuse with no batteries connected. AC "OK" light still on</p>	<p>Internal Short.</p>	<p>Return for analysis/repair by servicing dealer where charger was purchased or contact NEWMAR for a Return Materials Authorization number.</p>
<p>D) Reverse polarity connection At battery, green DC "OK" light extinguishes.</p>	<p>DC Output fuse and possibly other components blown.</p>	<p>Disconnect AC power. Check for proper battery polarity <u>at charger and at battery</u>. After correcting miswires, replace the two blown fuses with ATC-30 or ATO-30 automotive blade style fuses. If fuses blow again or DC "Ok" light extinguished or flashing, return to servicing dealer or contact NEWMAR for Return Materials Authorization.</p>



DC Power Onboard
Emergency & Specialty Vehicles

www.newmarEVpower.com

Condition	Possible Cause	Solution
E) EVM-12-1 meter does not work - LED's illuminate.	1) Remove polarity to meter 2) Remote meter connector terminals #3 & #1 shorted together due to meter mis-wiring 3) Open circuit wire disconnected	1) Meter is protected from reverse polarity. Correct wiring. 2) Immediately disconnect Remote Meter connector from charger - remove short and re-connect meter (prolonged short circuit may damage charger). 3) Check wiring for open connection.
F) EVM-12-1 bar graph works but "Charger On" LED does not	Remote meter connector terminals #3 & #4 shorted together or open wire	Remove short and re-connect EVM-12-1 meter
G) EVM-12-1 meter does not work and the DC "Ok" light is not on	Charger was damaged by prolonged meter mis-wiring - see section E-2 above.	Return for analysis/repair by servicing dealer where charger was purchased or contact NEWMAR for Return Authorization.
H) High output voltage measured across charger output terminals.	Batteries not connected to charger. It is normal to read 1/2 volt higher across any output bank when no batteries are connected	Check for tight connection of charging leads from charger to batteries.



DC Power Onboard
Emergency & Specialty Vehicles

www.newmarEVpower.com

VIII) BATTERY CARE TIPS

Regular maintenance and proper care will assure you reliable service from the most depended upon and sometimes most neglected items, your batteries and battery charger. NEWMAR battery chargers are designed to keep your batteries fully charged but your batteries also need proper regular maintenance to provide a maximum life of service.

ALWAYS READ AND FOLLOW THE BATTERY MANUFACTURER'S INSTRUCTIONS

Battery Installation

Batteries must be securely mounted to prevent them from falling over when the vehicle or boat is in motion. A loose battery can do serious damage. Batteries should be mounted in a battery box to contain any acid spill. Batteries give off a certain amount of hydrogen gas when they are charging. When concentrated, this gas is highly explosive. Therefore make sure they are in an accessible place with adequate ventilation for any hydrogen gas discharge.

Cleaning Batteries

Dirt and electrolyte salts can build up on the top of your batteries. This accumulation conducts electricity stored in the battery and can cause the battery to discharge by itself. Therefore, at least twice a year, it is a good idea to disconnect the battery cables and scrub the battery with a baking soda solution. Rinse with fresh water and dry with a clean cloth.

You may wish to purchase a set of terminal post corrosion prevention rings. These are alkali-saturated felt rings that slip over the battery post to reduce corrosion. Do not apply grease to any part of the battery terminals, but you may use an occasional light spray of silicone lubricant.

Routine Checks and Maintenance

Batteries should periodically be "exercised" (slowly discharged and then recharged) to keep them in top condition. New batteries may need to be exercised before they will be capable of their full rating.

If your batteries are not the sealed type, distilled water should be added to them whenever needed. The electrolyte should cover the plates by about 1/2", allowing a small air space at the top. Do not fill the cells up to the filler cap as this could cause the battery to sputter out electrolyte when it is being charged. Only distilled water should be used never plain tap water. Tap water contains chemicals and elements that can alter the properties of the electrolyte, including specific gravity. Some chemicals may also create an insulating coating on the battery plates which will retard current flow.

The rate that water is lost by the battery is dependent on several factors; battery condition, ambient temperature, battery use, charge voltage, etc. It is normal for batteries which are not maintenance-free to require topping off about once a month.

A battery's state of charge may be monitored by checking the specific gravity or by open circuit voltage. You may use the following table to evaluate the condition of your batteries:

Specific Gravity Measured by Hydrometer	Open Circuit Voltage		State of Discharge @ 80° F
	12 Volt System	24 Volt System	
1.265	12.6 or more	25.2 or more	Fully Charged
1.225	12.4	24.8	25% Discharged
1.190	12.2	24.4	50% Discharged
1.155	12.0	24.0	75% Discharged
1.120	11.7 or less	23.4 or less	100% Discharged

***Note: Wait at least 5 minutes after charging or discharging before checking specific gravity or open circuit voltage. The battery's voltage needs to stabilize in order to get an accurate reading.**

Troubleshooting Your Battery System

If your battery will not accept or hold a charge, one of the following conditions may exist:

1. A BAD BATTERY. You may have a battery with an open or shorted cell, a battery without any "life" left. Check by charging the battery until all cells have a specific gravity of 1.225 or greater at 80° F. If you are unable to obtain 1.225 in each cell, replace the battery. For maintenance-free or gel-cell batteries consult the manufacturer.

2. A BAD BATTERY CHARGER. If the battery open circuit voltage is low and/or the hydrometer indicates your batteries are low, the battery charger should be providing current to the batteries. If it is not, check AC input and check to see that you have charging voltage on the output with no battery attached. Note: You will not get an accurate voltage reading on the output of the charger with no batteries attached. This is checked merely to ensure that you do not have an open circuit on the output.

The battery charger has a thermal cutout switch to turn the charger off if it is overheating. If you suspect this is the case, refer to the information regarding charger location in the Installation section and cooling fans in the Application Notes section.

3. ELECTRICAL LEAKAGE. You may have a previously unsuspected source of current drain from the battery. To check for a leakage of this sort, disconnect the battery ground cable and connect an ammeter between the negative battery post and ground. If you have a reading over .1 amp, there is a source of current drain from the batteries which must be located and removed.



DC Power Onboard
Emergency & Specialty Vehicles

www.newmarEVpower.com

Unit Dimensional Drawing

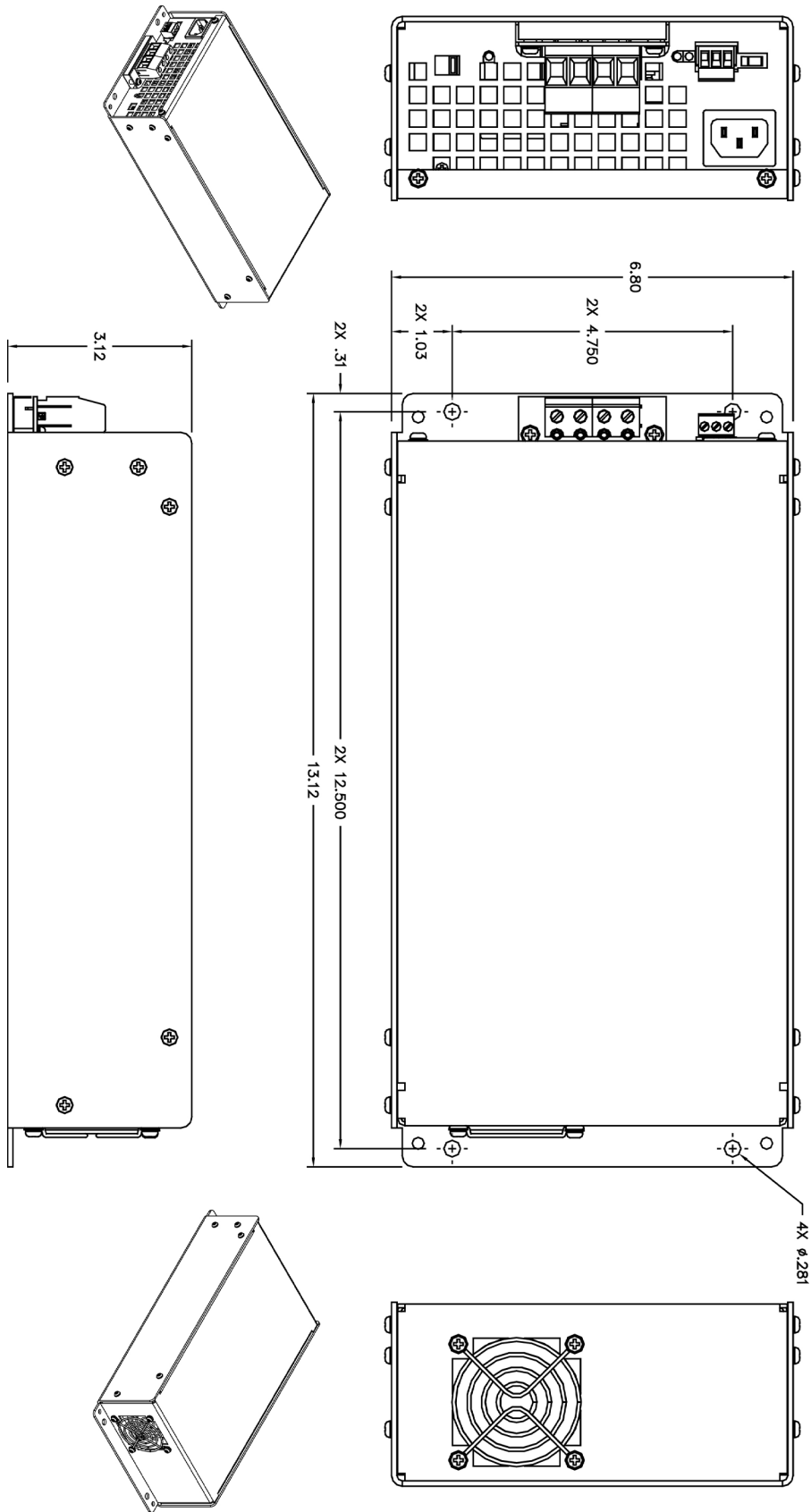

DC Power Onboard
Emergency & Specialty Vehicles

www.newmarEVpower.com